

# 1. Cabinet

## Exploded View

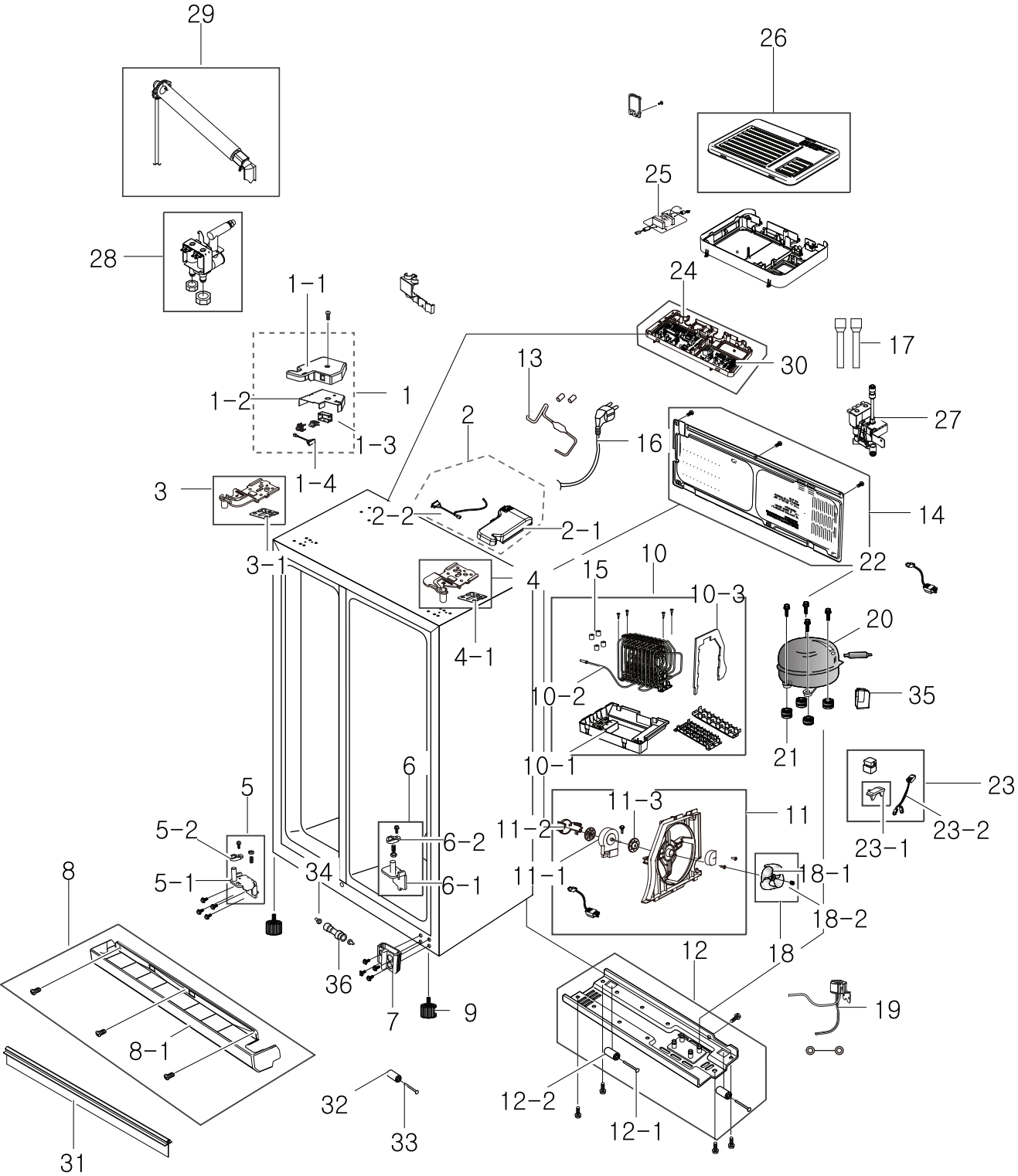

## Parts List

No.	Parent	Lvl.	Loc.	Material Code	Description & Specification	SNA	Qty.
1	DA90-05745A	2	RO044	DA97-08275A	ASSY COVER HINGE-UPP L; HM10,T2.5,156.1,2	SA	1
1-1	DA97-08275A	3	RK146	DA63-05289A	COVER HINGE-UPP L; HM10,ABS,T2.5,156.1,23	SA	1
1-2	DA97-08275A	3	RO250	DA61-06038A	PLATE-COVER HINGE; HM10,GI-SGCC,T0.4	SA	1
1-3	DA97-08275A	3	RO305	DA61-05274A	PLATE-DOOR SWITCH; AW2 CD,SGCC,T0.4,-,-,-	SA	1
1-4	DA97-11095A	3	RY459	DA34-00043C	SWITCH REED-ASS'Y; 200VDC,1.5A,-	SA	1
2	DA90-05745A	2	RO045	DA97-06159C	ASSY COVER HINGE-UPP R; GUGGENHEIM(EXP),-	SA	1
2-1	DA97-06159C	3	RO455	DA63-04180C	COVER HINGE-UPP R; GUGGENHEIM(EXP),N-ABS,	SA	1
2-2	DA97-11095A	3	RY459	DA34-00043C	SWITCH REED-ASS'Y; 200VDC,1.5A,-	SA	1
3	DA90-05745A	2	RO041	DA97-06156B	ASSY HINGE UPP-L; GUGGENHEIM(EXP),T3.0,-,	SA	1
3-1	DA97-06156B	3	RK777	DA63-50192A	SHIM-HINGE UPP; -,RD-PVC,T1.0,-,L360,-,-	SA	1
4	DA90-05745A	2	RO042	DA97-06155B	ASSY HINGE UPP-R; GUGGENHEIM(EXP),T3.0,-,	SA	1
4-1	DA97-06156B	3	RK777	DA63-50192A	SHIM-HINGE UPP; -,RD-PVC,T1.0,-,L360,-,-	SA	1
5	DA90-05745A	2	RO037	DA97-06158A	ASSY HINGE LOW-L; GUGGENHEIM,-,-,-,BLK,-,	SA	1
5-1	DA97-06158A	3	RO434	DA61-04191A	HINGE-LOW L; GUGGENHEIM,SHP1,T4.5,-,-,-,-	SA	1
5-2	DA97-06158A	3	RD200	DA66-00560A	CAM HINGE-RISER LOW L; GUGGENHEIM,PC(HF-1	SA	1
6	DA90-05745A	2	RO038	DA97-06157A	ASSY HINGE LOW-R; GUGGENHEIM,-,-,-,BLK,-,	SA	1
6-1	DA97-06157A	3	RO436	DA61-04190A	HINGE-LOW R; GUGGENHEIM,SHP1,T4.5,-,-,-,-	SA	1
6-2	DA97-06157A	3	RD201	DA66-00559A	CAM HINGE-RISER LOW R; GUGGENHEIM,NY-66,-	SA	1
7	DA90-05898E	2	RO500	DA61-06104A	BRACKET HINGE-LOW; HM10,AL,43.5,55.4,BLAC	SA	2
8	DA90-05745A	2	RO003	DA97-08351A	ASSY COVER LEG-FRONT; HM10,89.3,910.9	SA	1
8-1	DA97-08351A	3	RO287	DA63-05292A	COVER LEG-FRONT; HM10,PP,910.9,89.3,STS-K	SA	1
9	DA97-08325F	3	RO100	DA61-00805A	FOOT-FRONT; REF-ALL,PP,PI44,NTR,H65.8,-,B	SC	2
10	DA90-05743B	2	RH003	DA97-03869E	ASSY TRAY-DRAIN WATER; HERMES-PJT,-,W242.	SA	1

No.	Parent	Lvl.	Loc.	Material Code	Description & Specification	SNA	Qty.
10-1	DA97-03869E	3	RH885	DA63-03069B	TRAY DRAIN-WATER; HERMES-PJT,PP SCRAP,-,W	SA	1
10-2	DA97-03869E	3	RW002	DA97-03962C	ASSY PIPE-SPIRAL COND; HERMES-PJT,-	SA	1
10-3	DA97-03869E	3	RH030	DA97-05564A	ASSY-SEAL SUB CONDENSER; HERMES-PJT,-,-,-	SA	1
11	DA90-05743B	2	RO132	DA97-03870B	ASSY SUPPORT-CIRCUIT MOTOR; ET/ATOP_VE,-,	SA	1
11-1	DA97-03870B	3	RR088	DA31-00146B	MOTOR BLDC; DRCP5030LA,1560,-,DC12V,230mA	SC	1
11-2	DA97-03870B	3	RH039	DA61-02355B	BRACKET-CIRCUIT MOTOR; ABS,NEXT,-,-,-,NTR	SA	1
11-3	DA97-08285N	3	RR066	DA63-40167A	GROMMET-COVER CHIL; SILICON,L16,WHITE	SA	1
12	DA90-05743B	2	RO002	DA97-03971E	ASSY CHASSIS-COMP; HERMES,-,-,W255.5,L895	SA	1
12-1	DA97-08325F	3	RH012	DA61-01920A	CASTER-RIVET; (ZPC2),MSWR10,OD8.0,L54,-,-	SA	1
12-2	DA97-03971E	3	RR242	DA61-04703A	CASTER-REAR; AW-PJT,PP,-,35,NTR,35,PP+TPE	SA	2
13	DA90-05743B	2	RT094	DA97-02805D	ASSY PIPE CONNECT-SUCTION; GGH09	SA	1
14	DA90-05745A	2	RH001	DA97-05202H	ASSY COVER-COMP; HERMES,SBHG1,T0.3,SEAL C	SA	1
15	DA97-03962C	4	RX020	DA63-40171B	GROMMET-SUCT PIPE A; -,NBR,OD20,ID4,L20,-	SA	2
16	DA90-06661V	2	RK076	DA39-10115D	CBF-POWER CORD; UCP-2,250V,10/16A,L2100,-	SC	1
17	DA90-05743B	2	RR856	DA97-04045A	ASSY TUBE-DRAIN; ET-PJT,SOFT-PVC	SA	2
18	DA90-05743B	2	RK180	DA31-00010F	FAN-ASS'Y; SBS,ABS+GLASSFIBER, 150,3-Win	SA	1
18-1	DA31-00010F	3	RR029	DA31-00015C	FAN-TURBO; -,ET-PJT,ABS+GLASS FIBE,-,GR-4	SA	1
18-2	DA97-08285N	3	RR053	DA61-20128A	SPRING ETC-FAN; -,STS304,PI7.8,-,OD1.0,-,	SA	1
19	DA90-05743B	2	RF113	DA97-07070B	ASSY MOTOR-STEP VALVE; JM-PJT,-	SA	1
20	DA90-05743B	2	RH002	EU4A5QL2X/E01	COMPRESSOR; 15.31CC,BLDC,R-600A		1
21	DA90-05743B	2	RH732	DA63-02617A	GROMMET COMP; USP05,EPDM,OD18.5,BLACK	SA	4
22	DA90-05745A	2	RR963	6011-001656	BOLT-HEX; HWH,M6,L16,ZPC(WHT),SWRCH18A,MA	SA	6
23	DA90-05743B	2	RH070	DA97-08310F	ASSY COMP-SUB; WIRE HARNESS-COMP SUB,4TM3	SA	1
23-1	DA97-08310F	3	RO354	DA34-00004C	RELAY PROTECTOR O/L; 4TM319SFBYY-82,BK190	SA	1

Exploded Views and Parts List

No.	Parent	Lvl.	Loc.	Material Code	Description & Specification	SNA	Qty.
23-2	DA97-08310F	3	RH741	DA39-00154C	WIRE HARNESS-COMP; USP,PVC_TUBE,-,5,-,-,-	SA	1
24	RSH7UNPN1/XES	1	RY475	DA41-00640B	ASSY PCB MAIN; '09 HM-PJT, TOP OF REF,FR-4	SA	1
25	DA90-05743B	2	RH069	DA27-00004D	COIL FILTER; REACTOR,7.5MH,-,169,65.5*45*	SA	1
26	DA90-05745A	2	RO286	DA63-05419A	COVER PCB-PANEL; HAEMIL_CULLI,GI-SGCC,T0.	SA	1
27	DA90-05747B	2	RO089	DA97-07827C	ASSY VALVE WATER; HM10,220-240V	SA	1
28	DA97-07827C	3	RO521	DA62-02291C	VALVE WATER; HM10-INDOOR,POM,1.0~8.0K,GRA	SA	1
29	DA90-05747B	2	RO556	DA97-08596A	ASSY PIPE-WATER LINE; HM10,ASSY	SA	1
30	RSH7UNPN1/XES	1	RO326	DA41-00404J	ASSY PCB SUB INVERTER; 09 HERMES INDOOR,T	SA	1
31	DA97-08325F	3	RM102	DA64-02472A	TRIM-BLADE; HERMES-PJT,PVC,-,-,L375.2,NAT	SA	1
32	DA97-08325F	3	RO360	DA61-04702A	CASTER-FRONT; AW-PJT,PP,-,35,NTR,35,PP+TP	SA	1
33	DA97-08325F	3	RH012	DA61-01920A	CASTER-RIVET; (ZPC2),MSWR10,OD8.0,L54,-,-	SA	1
34	DA90-05747B	2	RM019	DA71-20207A	FIXER-VALVE WATER A; SR-S7180,NY-6,OD7.8	SA	2
35	DA90-05743B	2	RH015	DA63-01866A	COVER RELAY; NORYL,T2.0,SSEC,BLACK,HOOK	SA	1
36	DA90-05747B	2	RY761	DA60-00258B	FITTING-TUBE FITTING; TUBE FITTING A,PC,3	SA	1

# 2. Freezer

## Exploded View

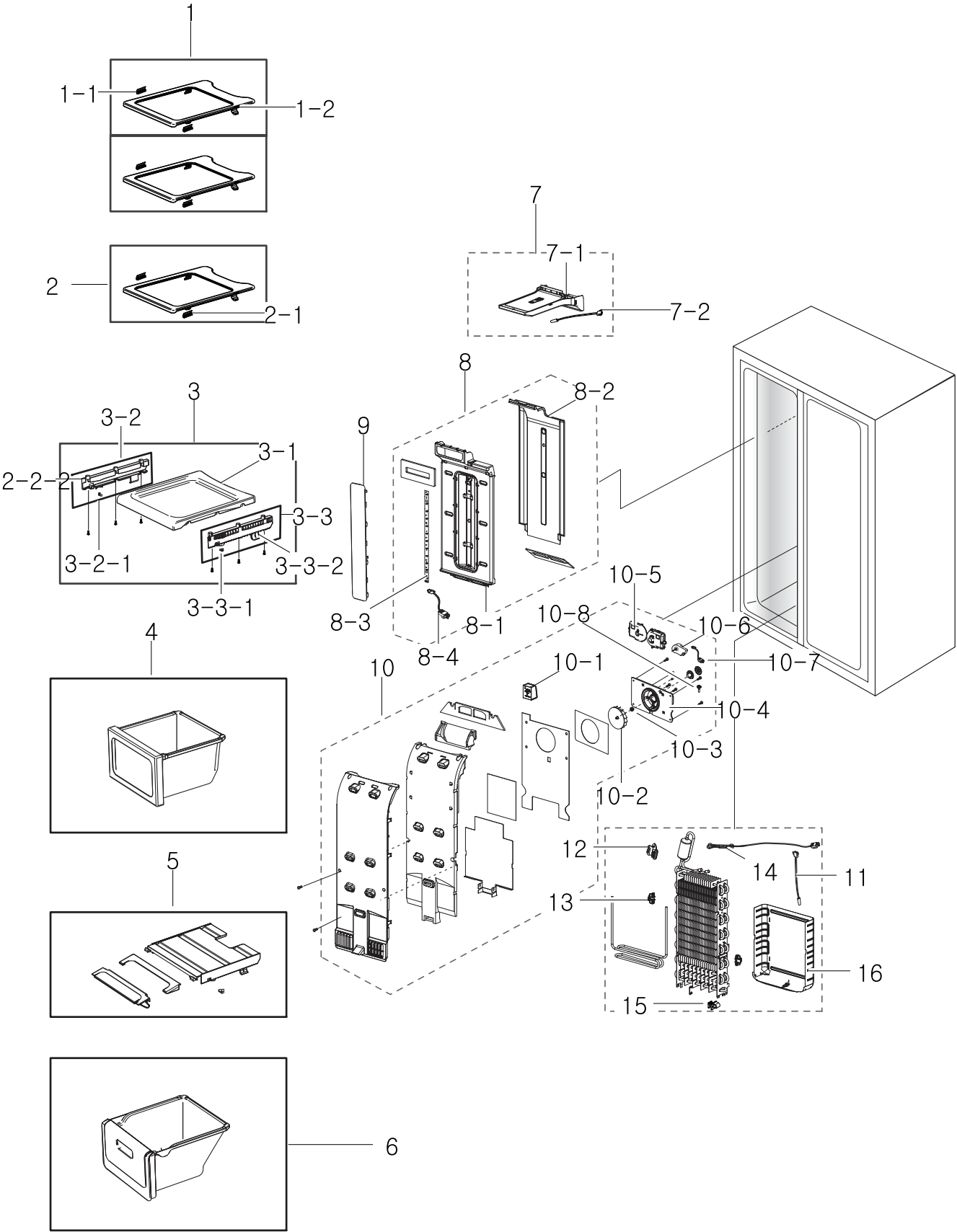

**Parts List**

No.	Parent	Lvl.	Loc.	Material Code	Description & Specification	SNA	Qty.
1	DA90-05707B	2	RR853	DA97-08274A	ASSY SHELF FRE-TOP; HM10	SA	2
1-1	DA97-08274A	3	RK889	DA64-02870A	TRIM-SHELF; CULLI_09,LDPE,FB3000,-,L30,WH	SA	4
1-2	DA97-08274A	3	RF297	DA67-02465A	SHELF FRE-TOP; HM10,HIPS,306.6,349.8,COOL	SA	2
2	DA90-05707B	2	RE064	DA97-08044A	ASSY SHELF FRE-MID; HERMES,HIPS,TEMPERED	SA	1
2-1	DA97-08274A	3	RK889	DA64-02870A	TRIM-SHELF; CULLI_09,LDPE,FB3000,-,L30,WH	SA	4
2-2-2	DA97-05234B	4	RK243	DA63-00202C	GROMMET-RAIL; TD-PJT,NY-66,W10.7,L15,COOL	SA	1
3	DA90-05707B	2	RF022	DA97-06927A	ASSY-SHELF FRE LOW; HERMES-PJT,-,-,-	SA	1
3-1	DA97-06927A	3	RF360	DA67-02110A	SHELF-FRE LOW; HERMES-PJT,HIPS,-,-,-,COOL	SA	1
3-2	DA97-06928A	3	RR838	DA97-05233B	ASSY RAIL-BOX L; HERMES-PJT,T2.0,W17,L260	SA	1
3-2-1	DA97-05233B	4	RK458	DA61-03413B	RAIL-BOX L; HERMES-PJT,TALC PP,-,-,-,NATU	SA	1
3-3	DA97-06928A	3	RR840	DA97-05234B	ASSY RAIL-BOX R; HERMES-PJT,T2.0,W17,L260	SA	1
3-3-1	DA97-05234B	4	RK460	DA61-03412B	RAIL-BOX R; HERMES-PJT,TALC PP,-,-,-,NATU	SA	1
3-3-2	DA97-05234B	4	RK243	DA63-00202C	GROMMET-RAIL; TD-PJT,NY-66,W10.7,L15,COOL	SA	1
4	DA90-05740B	2	RI248	DA97-05047B	ASSY-CASE BASKET HIGH; HERMES,GPPS+HIPS,-	SA	1
5	DA90-05740B	2	RI249	DA97-05049C	ASSY-COVER SLIDE BASKET; HERMES,ABS+HIPS,	SA	1
6	DA90-05740B	2	RI170	DA97-05046B	ASSY-CASE BASKET LOW; HERMES,GPPS+HIPS,-,	SA	1
7	DA90-05744B	2	RI027	DA97-08256A	ASSY COVER-ICE DUCT FRE; HM10,IN_DOOR,PP,	SA	1
7-1	DA97-08256A	3	RG179	DA63-05296A	COVER-ICE DUCT FRE; HM10,PP,COOL-WHITE(SC	SA	1
7-2	DA97-08257C	3	RK732	DA32-10105U	SENSOR TEMP; 502AT,A-TOP,-50~50,5V,-,-,RO	SA	1
8	DA90-05744B	2	RF439	DA97-08258B	ASSY COVER-MULTI FRE; HM10,IN_DOOR,LED,PP	SA	1
8-1	DA97-08258B	3	RD291	DA63-05294A	COVER-MULT FRE; HM10,PP,COOL-WHITE(SC-027	SA	1
8-2	DA97-08258B	3	RD290	DA61-05713A	PLATE-INS MULT FRE; HM10,ABS,COOL-WHITE(S	SA	1
8-3	DA97-08258B	3	RY233	DA41-00749C	PBA-LED LAMP; HAEMIL,F-ROOM,FR-4,335X20X1	SA	1

No.	Parent	Lvl.	Loc.	Material Code	Description & Specification	SNA	Qty.
8-4	DA97-08257C	3	RR867	DA96-00424F	ASSY W/HARNESS-LED LAMP; NEXT08,W/H LED L	SA	1
9	DA90-05740B	2	RF396	DA63-05297A	COVER-LAMP FRE; HM10,LED,PP,NTR	SA	1
10	DA90-05744B	2	RF005	DA97-05052M	ASSY-COVER EVAP FRE; HERMES10	SA	1
10-1	DA97-08285N	3	RI222	DA63-04657A	COVER-FIXER HOUSING V; HERMES,SAZCC,T0.3,	SA	1
10-2	DA97-05052M	3	RK182	DA31-00053A	FAN-BACKWARD; -,A-TOP,ABS,-,FRE	SA	1
10-3	DA97-08285N	3	RR053	DA61-20128A	SPRING ETC-FAN; -,STS304,PI7.8,-,OD1.0,-,	SA	1
10-4	DA97-05052M	3	RY172	DA61-00417A	CASE MOTOR; A-TOP,ABS SCRAP,-,-,-,WHT,SBS	SA	1
10-5	DA97-08285N	3	RF455	DA63-01809A	COVER MOTOR-BLDC; BLDC-NEW,PP,NTR,-,-,-,-	SA	1
10-6	DA97-08285N	3	RF431	DA31-00146E	MOTOR FAN-BLDC; DREP5020LB,BLDC Motor,0.2	SA	1
10-7	DA97-08285N	3	RY711	DA39-00060B	WIRE HARNESS-MOTOR; -,-,-,-,-,F-FAN,-,-	SC	1
10-8	DA97-08285N	3	RR066	DA63-40167A	GROMMET-COVER CHIL; SILICON,L16,WHITE	SA	1
11	DA96-00675J	3	RR336	DA32-00029N	SENSOR TEMP; DTN-C502G6X,NEXT-PJT,40~110	SA	1
12	DA96-00675J	3	RK215	DA61-00603A	FIXER-SENSOR; n-PJT,PP,-,-,-	SA	1
13	DA96-00676G	3	RF217	DA61-05160A	FIXER-FUSE; CULLI_09,PP,BJ-730,NTR,-	SA	1
14	DA96-00675J	3	RR342	DA47-00301F	THERMO FUSE-ASSY; TWIN,120V/250V,15A/10A,	SA	1
15	DA96-00676G	3	RR006	DA61-06013A	FIXER-WIRE; AW3-PJT,PP,NTR	SA	2
16	DA96-00675J	3	RF169	DA61-05989B	PLATE-DRAIN EVAP FRE; HERMES,GL-SAZCC,T0.	SA	1

# 3. Freezer Door

## Exploded View

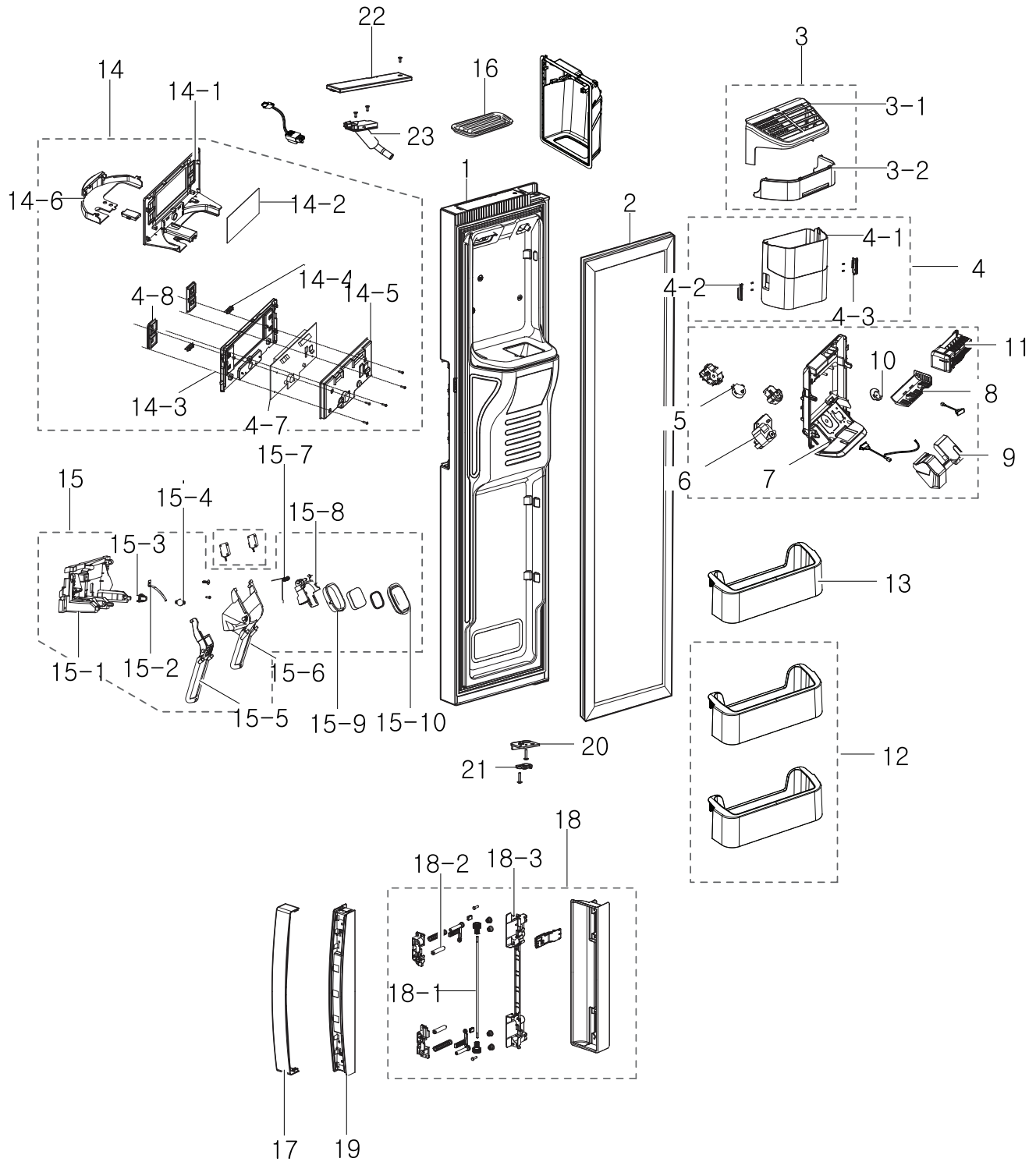



## Parts List

No.	Parent	Lvl.	Loc.	Material Code	Description & Specification	SNA	Qty.
1	DA90-05900E	2	RD001	DA91-02985B	ASSY DOOR FOAM FRE; HM10,75MM, DISP,230V,	SA	1
2	DA90-05900E	2	RR901	DA97-04567C	ASSY-GASKET DOOR FRE; A-TOP,SC-97487,-,-	SA	1
3	DA90-05747B	2	RM003	DA97-08276A	ASSY COVER-ICE MAKER; HM10,135.6,299.4,CO	SA	1
3-1	DA97-08276A	3	RM067	DA63-05290A	COVER-ICE MAKER A; HM10,ABS,135.6,299.4,C	SA	1
3-2	DA97-08276A	3	RM068	DA63-05291A	COVER-ICE MAKER B; HM10,SAN,124.3,293.9,N	SA	1
4	DA90-05747B	2	RF304	DA97-06569H	ASSY TRAY-ICE BUCKET; GGH/HM,COOL WHITE,I	SA	1
4-1	DA97-06569H	3	RM050	DA64-02587A	WINDOW-BUCKET; GUGGENHEIM,PC,-,288.8,117,	SA	1
4-2	DA97-06569H	3	RM051	DA66-00587A	LEVER-BUCKET L; GUGGENHEIM,ABS,29.8,76.7,	SA	1
4-3	DA97-06569H	3	RM052	DA66-00588A	LEVER-BUCKET R; GUGGENHEIM,ABS,29.8,76.7,	SA	1
4-7	DA97-08015U	3	RY208	DA41-00643B	ASSY PCB KIT LED; '09 HM-PJT INDOOR,F-DOO	SA	1
4-8	DA97-08015U	3	RD236	DA63-05059A	GROMMET-BUTTON; HM09,SILICON,BLACK	SA	2
5	DA97-11095A	3	RF261	DA31-00079A	MOTOR GEARED-DISP; 15.2/18.2 rpm,50/60Hz,	SA	1
6	DA97-11095A	3	RF434	DA31-00210E	MOTOR GEARED-AUGER; ISG-3245SSB,1/201.5,2	SA	1
7	DA97-11095A	3	RF417	DA61-04363B	CASE-AUGER MOTOR; HM10,GGH,ABS,171.8,415.	SA	1
8	DA97-11095A	3	RI379	DA63-04355A	COVER-HEATER ICE MAKER; GUGGENHEIM,ABS,47	SA	1
9	DA97-11095A	3	RF251	DA63-04362B	COVER-MOTOR AUGER SUB; GUGGENHEIM,HIPS,NT	SA	1
10	DA97-11095A	3	RF185	DA66-00589A	CAM-LEVER CUBE; GUGGENHEIM,POM,T17.9,55	SA	1
11	DA97-11095A	3	RM061	DA97-07549A	ASSY ICE MAKER; GUGGENHEIM,220~240V,50Hz,	SA	1
12	DA90-05746B	2	RI141	DA97-08271A	ASSY GUARD-FRE LOW; HM10,INDOOR, 75MM	SA	2
13	DA90-05747B	2	RD351	DA63-05013B	GUARD FRE-UPP; HM10,HIPS,2-STAR	SA	1
14	DA90-05900E	2	RD026	DA97-08015U	ASSY COVER-DISPENSER; HM10,VERSAILLES STS	SA	1
14-1	DA97-08015U	3	RR163	DA63-05054C	COVER-DISPENSER; HM09,ABS,VERSAILLES STS,	SA	1
14-2	DA97-08015U	3	RD052	DA63-05063A	COVER-CONTROL WINDOW FRE; HM09,ACRYL,NTR,	SA	1

## Exploded Views and Parts List

No.	Parent	Lvl.	Loc.	Material Code	Description & Specification	SNA	Qty.
14-3	DA97-08015U	3	RD245	DA63-05058B	COVER-PBA PANEL DISPENSER; HM10,HIPS,NTR	SA	1
14-4	DA97-08015U	3	RD286	DA64-02983A	DECORATION-BUTTON CONTROL; HM09,ABS,NTR,P	SA	2
14-5	DA97-08015U	3	RD285	DA63-05057B	COVER-DISPENSER SUB; HM10,HIPS,NTR	SA	1
14-6	DA97-08015U	3	RD243	DA64-02982C	BUTTON-DISPENSER; HM09,ABS,NOBLE GRAY,VER	SA	1
15	DA90-05900E	2	RD463	DA97-07774A	ASSY COVER-PCB PANEL REAR; HM09,ASSY,SAN(	SA	1
15-1	DA97-07774A	3	RO464	DA63-03259C	COVER PCB-PANEL REAR; A-TOP 06,ABS(HG-076	SA	1
15-2	DA97-07774A	3	RD446	DA61-01616A	SPRING ETC-LEVER DISP WATER; AD,STS304,-,	SA	1
15-3	DA97-07774A	3	RD448	DA61-01868B	BRACKET-OIL DAMPER; ABS,AD,-,-,-,NTR,-	SA	1
15-4	DA97-07774A	3	RO353	DA61-01869A	OIL DAMPER; AD,POM,-,120g/Cm,-,OD15,-,-	SA	1
15-5	DA97-07774A	3	RD284	DA66-00685A	LEVER-DISPENSER WATER; HM09,SAN,NTR	SA	1
15-6	DA97-07774A	3	RD283	DA66-00684A	LEVER-DISPENSER ICE; HM09,SAN,NTR	SA	1
15-7	DA97-07774A	3	RD050	DA61-01651A	SPRING ETC-COVER ICE ROUTE; AD,STS304,1.0	SA	1
15-8	DA97-07774A	3	RD359	DA63-01970A	COVER-ICE ROUTE A; AD,ABS,T2.5,-,-,-,BL	SA	1
15-9	DA97-07774A	3	RD461	DA63-01971B	COVER-ICE ROUTE B; AD,ABS,-,-,-,-,NATUR	SA	1
15-10	DA97-07774A	3	RD051	DA63-01972A	GASKET-COVER ICE ROUTE; AD,SILICON,T1.5,-	SA	1
16	DA90-05900E	2	RO489	DA63-03580X	TRAY DISPENSER; HERMES,ABS,T2.5,DISP,SC-0	SA	1
17	DA90-05901G	2	RE102	DA64-03166C	TRIM-HANDLE; HM10,A6063,VERSAILLES STS(SC	SA	1
18	DA97-08282T	4	RD288	DA97-08290M	ASSY CASE-HANDLE FRONT; HM10,VERSAILLES S	SA	1
18-1	DA97-08290M	5	RD282	DA66-00713B	SHAFT-GEAR EASY; HM10,MSWR10,247,4.5	SA	1
18-2	DA97-08290M	5	RD211	DA66-00726A	SHAFT-HANDLE; HM10,STS303,OD9	SA	2
18-3	DA97-08290M	5	RE283	DA64-03164A	HANDLE BASE-EASY; HM10,ABS,27.9,336.1,NOB	SA	1
19	DA97-08521A	3	RD287	DA64-03163A	HANDLE-FRONT EASY; HM10,ABS,40.3,352,NOBL	SA	1
20	DA97-08277A	5	RD070	DA61-04195A	STOPPER-DOOR L; GUGGENHEIM,SHP1,T3.0,-,-,	SA	1
21	DA97-08277A	5	RD202	DA66-00558A	CAM HINGE-RISER UPP L; GUGGENHEIM,PC(HF-1	SA	1

No.	Parent	Lvl.	Loc.	Material Code	Description & Specification	SNA	Qty.
22	DA97-07731F	5	RO231	DA63-04341A	COVER-CAP DOOR FRE; GUGGENHEIM,ABS,-,W61.	SA	1
23	DA97-07731F	5	RO131	DA97-06542A	ASSY PIPE-WATER ICE; GUGGENHEIM(EXP),230V	SA	1

# 4. Fridge

## Exploded View

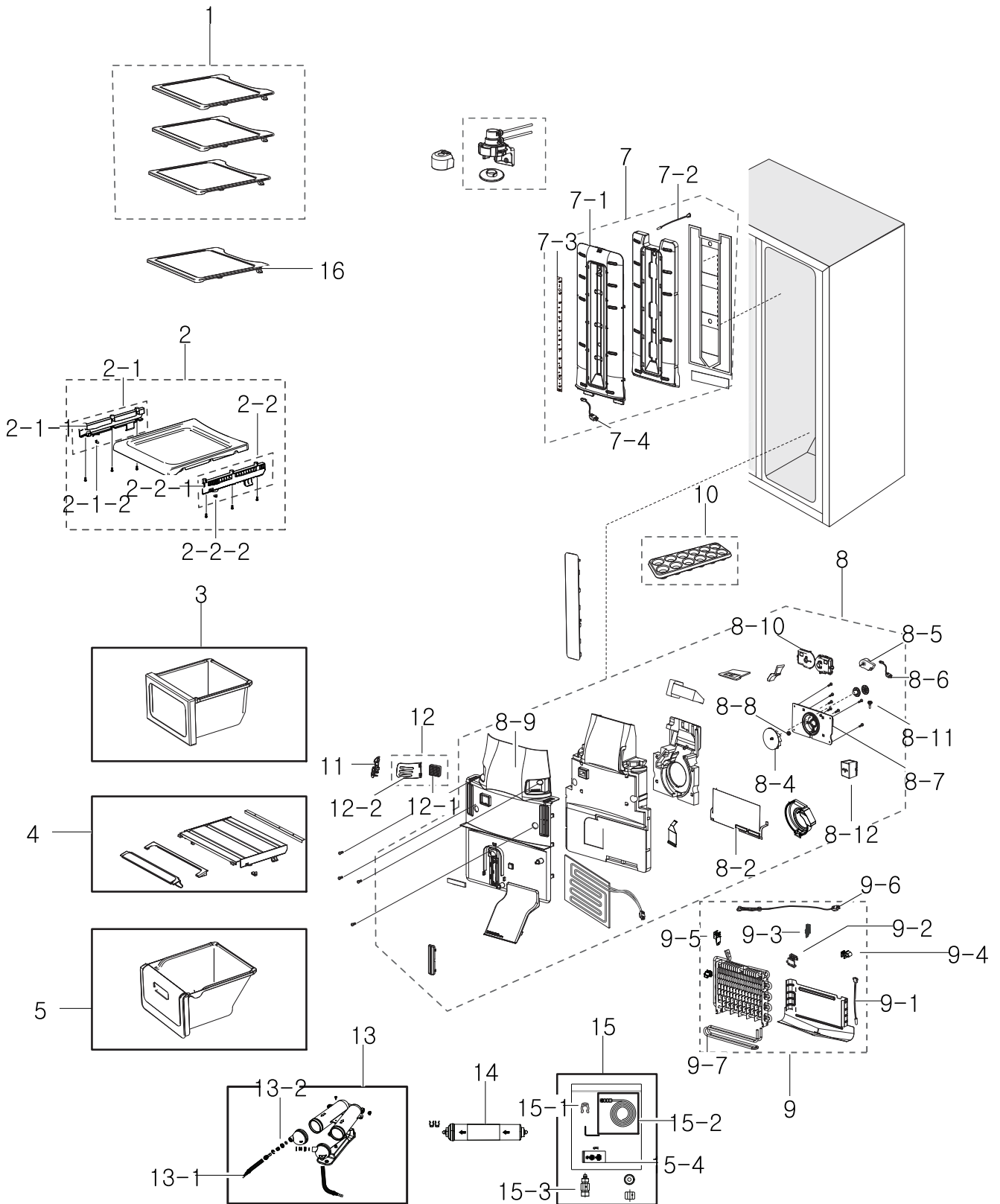

## Parts List

No.	Parent	Lvl.	Loc.	Material Code	Description & Specification	SNA	Qty.
1	DA90-05707B	2	RI672	DA67-01694A	SHELF REF-TOP; HERMES-PJT,PP+GLASS,T2.0,	SA	3
2	DA90-05707B	2	RI039	DA97-06928A	ASSY-SHELF REF LOW; HERMES,-,-,-	SA	1
2-1	DA97-06928A	3	RR838	DA97-05233B	ASSY RAIL-BOX L; HERMES-PJT,T2.0,W17,L260	SA	1
2-1-1	DA97-05234B	4	RK243	DA63-00202C	GROMMET-RAIL; TD-PJT,NY-66,W10.7,L15,COOL	SA	1
2-1-2	DA97-05233B	4	RK458	DA61-03413B	RAIL-BOX L; HERMES-PJT,TALC PP,-,-,-,NATU	SA	1
2-2	DA97-06928A	3	RR840	DA97-05234B	ASSY RAIL-BOX R; HERMES-PJT,T2.0,W17,L260	SA	1
2-2-1	DA97-05234B	4	RK243	DA63-00202C	GROMMET-RAIL; TD-PJT,NY-66,W10.7,L15,COOL	SA	1
2-2-2	DA97-05234B	4	RK460	DA61-03412B	RAIL-BOX R; HERMES-PJT,TALC PP,-,-,-,NATU	SA	1
3	DA90-05740B	2	RI087	DA97-05045B	ASSY-CASE VEG HIGH; HERMES,GPPS+HIPS,-,-	SA	1
4	DA90-05740B	2	RG143	DA97-05048D	ASSY-COVER SLIDE VEG; HERMES,ABS+HIPS,WRA	SA	1
5	DA90-05740B	2	RI001	DA97-05044B	ASSY-CASE VEG LOW; HERMES,GPPS+HIPS,-,-	SA	1
7	DA90-05744B	2	RI019	DA97-08257C	ASSY COVER-MULTI REF; HM10,IN_DOOR,LED,PP	SA	1
7-1	DA97-08257C	3	RI528	DA63-05295A	COVER-MULT REF; HM10,PP,COOL-WHITE(SC-027	SA	1
7-2	DA97-08257C	3	RK732	DA32-10105U	SENSOR TEMP; 502AT,A-TOP,-50~50,5V,-,-,RO	SA	1
7-3	DA97-08257C	3	RY223	DA41-00749D	PBA-LED LAMP; HAEMIL,R-ROOM,FR-4,490X20X1	SA	1
7-4	DA97-08257C	3	RR867	DA96-00424F	ASSY W/HARNESS-LED LAMP; NEXT08,W/H LED L	SA	1
8	DA90-05744B	2	RI008	DA97-08285N	ASSY COVER-EVAP REF; HM10,BASIC,LED,230V	SA	1
8-2	DA97-08285N	3	RI529	DA61-05993B	PLATE-EVAP HEATER REF; HERMES,AL,T0.3	SA	1
8-4	DA97-05052M	3	RK182	DA31-00053A	FAN-BACKWARD; -,A-TOP,ABS,-,FRE	SA	1
8-5	DA97-08285N	3	RF431	DA31-00146E	MOTOR FAN-BLDC; DREP5020LB,BLDC Motor,0.2	SA	1
8-6	DA97-08285N	3	RY711	DA39-00060B	WIRE HARNESS-MOTOR; -,-,-,-,-,F-FAN,-,-	SC	1
8-7	DA97-08285N	3	RF121	DA61-05286B	CASE-MOTOR REF; HERMES 09,HIPS,NTR	SA	1
8-8	DA97-08285N	3	RR053	DA61-20128A	SPRING ETC-FAN; -,STS304,PI7.8,-,OD1.0,-,	SA	1

Exploded Views and Parts List

No.	Parent	Lvl.	Loc.	Material Code	Description & Specification	SNA	Qty.
8-9	DA97-08285N	3	RI616	DA63-03594A	COVER EVAP-REF; HERMES,PP,-,-,-,-,-,COOL	SNA	1
8-10	DA97-08285N	3	RF455	DA63-01809A	COVER MOTOR-BLDC; BLDC-NEW,PP,NTR,-,-,-,-	SA	1
8-11	DA97-08285N	3	RR066	DA63-40167A	GROMMET-COVER CHIL; SILICON,L16,WHITE	SA	1
8-12	DA97-08285N	3	RI222	DA63-04657A	COVER-FIXER HOUSING V; HERMES,SAZCC,T0.3,	SA	1
9	DA90-05743B	2	RI016	DA96-00676G	ASSY EVAP REF; HERMES,230V,140W,SHEATH HE	SA	1
9-1	DA96-00676G	3	RK704	DA32-00029R	SENSOR TEMP; DTN-C502G6X,SSEDA-PJT,40~110	SA	1
9-2	DA96-00676G	3	RK213	DA61-03683A	FIXER-SENSOR; AW-PJT,PP,-,NTR,FH-44N	SA	1
9-3	DA96-00676G	3	RF217	DA61-05160A	FIXER-FUSE; CULLI_09,PP,BJ-730,NTR,-	SA	1
9-4	DA96-00676G	3	RR006	DA61-06013A	FIXER-WIRE; AW3-PJT,PP,NTR	SA	2
9-5	DA96-00676G	3	RC049	DA61-06062A	PLATE-EVAP BRACKET REF; HERMES/GUGGENHEIM	SA	1
9-6	DA96-00676G	3	RR341	DA47-00301B	THERMO FUSE-ASSY; HERMES,120V/250V,15A/10	SA	1
9-7	DA96-00676G	3	RF205	DA47-00321B	HEATER SHEATH-METAL REF; HM10-PJT,INCOLOY	SA	1
10	DA90-05740B	2	RE355	DA67-40322A	TRAY-EGG; SR-51.55.59,GPPS,-,-,-,-,-,-	SA	1
11	DA90-05740B	2	RG130	DA63-03605A	COVER-DEODORIZER L; HERMES,PP,-,-,-,-,-,C	SA	1
12	DA90-05740B	2	RI273	DA97-05065B	ASSY-COVER DEODORIZER R; HERMES,-,-,-	SA	1
12-1	DA97-05065B	3	RG022	DA02-90106P	CATALYST-LTC; NEXT,-,-,T7,W40,L40,-,-,SS6	SA	1
12-2	DA97-05065B	3	RG131	DA63-03606A	COVER-DEODORIZER R; HERMES,PP,-,-,-,-,-,C	SA	1
13	DA90-05747B	2	RI043	DA97-08536A	ASSY TANK WATER; HM10,ASSY,NTR	SA	1
13-1	DA97-08536A	3	RK444	DA62-02429L	PIPE-WATER LINE; LLDPE,7.93,L1260	SA	1
13-2	DA97-08536A	3	RM071	DA63-04630A	GROMMET-RING; AW,NBR,NTR	SA	2
14	DA90-05747B	2	RI070	DA29-10105J	FILTER WATER-ASSY; -,SBS ALL,-,-,-,-,-,-,	SA	1
15	DA90-05747B	2	RI069	DA97-05926M	ASSY-INSTALL FILTER; HM10,INDOOR	SA	1
15-1	DA97-05926M	3	RR094	DA61-04522A	CLIP-FITTING LOCK; AW,POM,-,-,1/4inch	SA	4
15-2	DA97-05926M	3	RR821	DA97-00753D	ASSY PIPE-WATER; A-TOP,INVERTER,L5.5MT	SA	1
15-3	DA97-00753D	4	RR072	DA74-00070B	VALVE-FITTING NUT; A-TOP,CU,12,-,-,-,-	SA	2

No.	Parent	Lvl.	Loc.	Material Code	Description & Specification	SNA	Qty.
15-4	DA97-05926M	3	RC001	DA62-01329A	PIPE-CONNECT WATER PACKING; ET-PJT,BRASS,	SA	1
16	DA90-05707B	2	RI664	DA67-02109A	SHELF REF-MID; HERMES-PJT,PP+GLASS,-,W443	SA	1

# 5. Fridge Door

## Exploded View

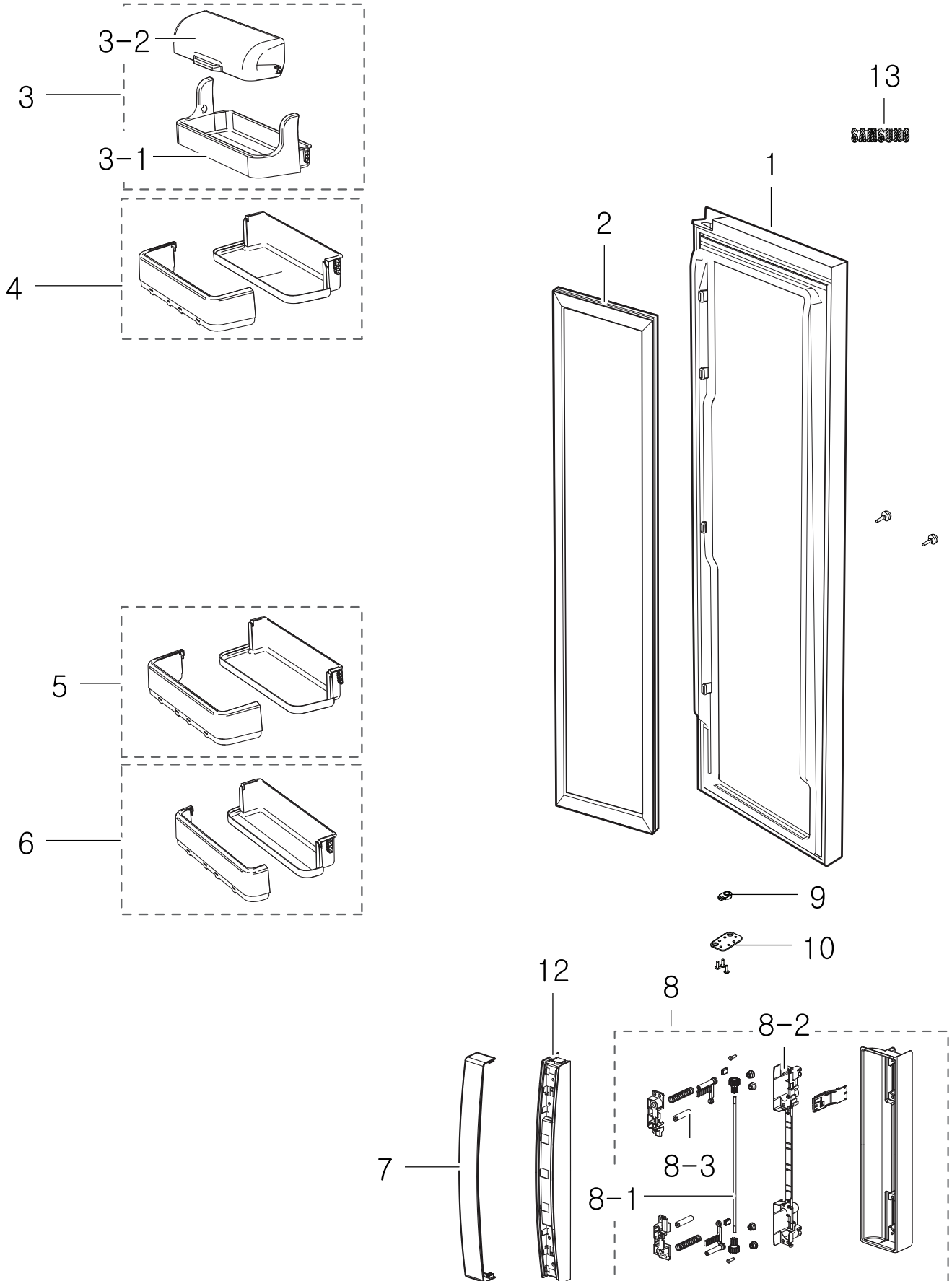



## Parts List

No.	Parent	Lvl.	Loc.	Material Code	Description & Specification	SNA	Qty.
1	DA90-05901G	2	RE001	DA91-02989K	ASSY DOOR FOAM REF; HM10,75MM,BASIC,230V,	SA	1
2	DA90-05901G	2	RR238	DA97-04567D	ASSY-GASKET DOOR REF; A-TOP,SC-97487,-,-	SA	1
3	DA90-05746B	2	RE028	DA97-08267A	ASSY GUARD-DAIRY; HM10,INDOOR, 75MM	SA	1
3-1	DA97-08267A	3	RE390	DA63-05282A	GUARD-DAIRY; HM10,HIPS,COOL WHITE(SC-0308	SA	1
3-2	DA97-08267A	3	RE386	DA63-03645A	COVER-GUARD DAIRY; HERMES PJT,GPPS,T2.5,-	SA	1
4	DA90-05746B	2	RE362	DA97-08268A	ASSY GUARD-REF TOP; HM10,INDOOR, 75MM	SA	1
5	DA90-05746B	2	RE362	DA97-08268C	ASSY GUARD-REF TOP; HM10,INDOOR,75MM,BASI	SA	1
6	DA90-05746B	2	RI161	DA97-08270A	ASSY GUARD-REF LOW; HM10,INDOOR, 75MM	SA	1
7	DA90-05901G	2	RE102	DA64-03166C	TRIM-HANDLE; HM10,A6063,VERSAILLES STS(SC	SA	1
8	DA97-08282T	4	RD288	DA97-08290M	ASSY CASE-HANDLE FRONT; HM10,VERSAILLES S	SA	1
8-1	DA97-08290M	5	RD282	DA66-00713B	SHAFT-GEAR EASY; HM10,MSWR10,247,4.5	SA	1
8-2	DA97-08290M	5	RE283	DA64-03164A	HANDLE BASE-EASY; HM10,ABS,27.9,336.1,NOB	SA	1
8-3	DA97-08290M	5	RD211	DA66-00726A	SHAFT-HANDLE; HM10,STS303,OD9	SA	2
9	DA97-08273A	5	RD203	DA66-00557A	CAM HINGE-RISER UPP R; GUGGENHEIM,NY-66,-	SA	1
10	DA97-08273A	5	RE439	DA61-04196A	STOPPER-DOOR R; GUGGENHEIM,SHP1,T3.0,-,-,	SA	1
12	DA90-05901G	2	RO222	DA97-08521A	ASSY HANDLE-FRONT; HM10,EASY-HANDLE	SA	1
13	DA90-06661V	2	RO716	DA64-01985A	MASCOT; SBS,AL,T1.5,L90,Fixing-type,Siver	SC	1