

EXPLODED VIEW PART LIST

Freezer

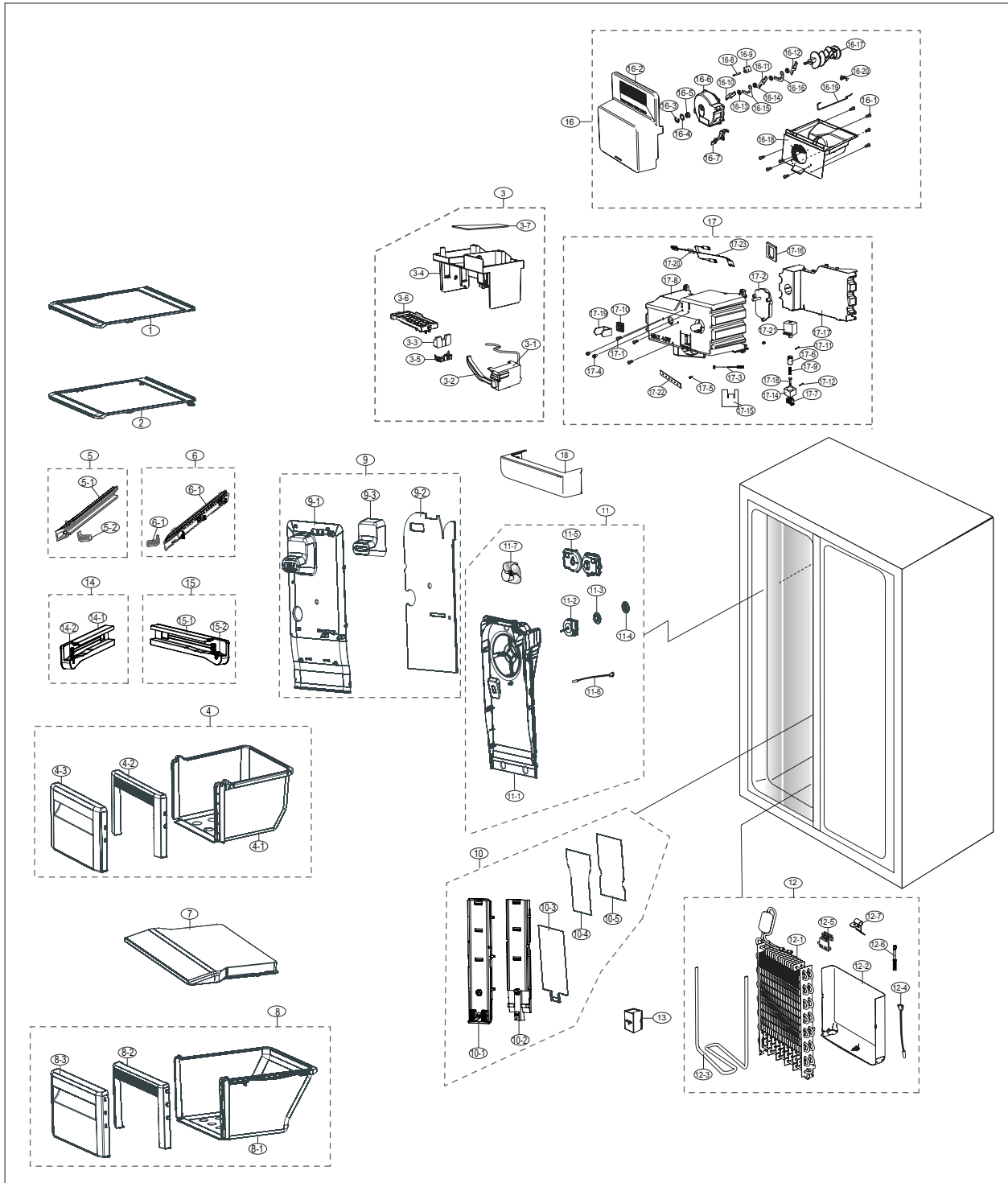

EXPLODED VIEW PART LIST

• Parts List of Freezer

NO	CODE NO	PART NAME	Specification	Quantity	Unit	SA/SNA
1	DA67-03362A	SHELF FRE-HIGH	ES-PJT,SSEC,PP+GLASS,COOL WHITE	2	PC	SA
2	DA67-03363A	SHELF FRE-LOW	ES-PJT,SSEC,PP+GLASS,COOL WHITE	2	PC	SA
3	DA97-05071B	ASSY ICE MAKER-MECH	HERMES,-,-,-,-,-	1	PC	SA
4	DA97-14362A	ASSY CASE BASKET-UP	ES-PJT,SSEC	1	PC	SA
4-1	DA61-04009A	CASE-BASKET HIGH	ES-PJT,SSEC,PP	1	PC	SNA
4-2	DA63-04045A	COVER-BASKET FORNT HIGH B	ES-PJT,SSEC,HIPS,COOL WHT	1	PC	SNA
4-3	DA63-04044B	COVER AIR	ES-PJT,SSEC,GPPS,HB,-,PG383M,transparency,BLUE	1	PC	SA
5	DA97-01291B	ASSY RAIL-BASKET L(ET)	ES-PJT,NATURAL	1	PC	SA
5-1	DA61-00044C	RAIL-BASKET L(ET)	ET-PJT,HIPS,NATURAL	1	PC	SNA
5-2	DA63-05275A	GROMMET-RAIL	ES-PJT,SSEC,PA6,SC-93437R	1	PC	SNA
6	DA97-01292B	ASSY RAIL-BASKET R(ET)	ES-PJT,NATURAL	1	PC	SA
6-1	DA61-00045C	RAIL-BASKET R(ET)	ET-PJT,HIPS,NATURAL,S834S1	1	PC	SNA
6-2	DA63-05275A	GROMMET-RAIL	ES-PJT,SSEC,PA6,SC-93437R	1	PC	SNA
7	DA63-03960A	COVER-BASKET HIGH	ES-PJT,SSEC,HIPS,-,-,-,-,-,COOL WHT,-	1	PC	SA
8	DA97-14363A	ASSY CASE BASKET-LOW	ES-PJT,SSEC	1	PC	SA
8-1	DA61-04046A	CASE-BASKET LOW	ES-PJT,SSEC,PP	1	PC	SNA
8-2	DA63-04042A	COVER-BASKET FRONT LOW B	ES-PJT,SSEC,HIPS,-,-,L298,-,-,COOL WHT,-	1	PC	SNA
8-3	DA63-04040B	COVER AIR	ES-PJT,SSEC,GPPS,HB,-,PG383M,transparency,BLUE	1	PC	SA
9	DA97-06068B	ASSY COVER MULTI-FRE FRONT	ES,SSEC,ICE MAKER	1	PC	SA
9-1	DA63-04022B	COVER-MULTI FRE FRONT	ES-PJT,SSEC,PP,-,COOL WHITE,BASIC	1	PC	SA
9-2	DA62-01823A	SEAL-MULTI FRE FRONT	ES-PJT,SSEC,PE FOAM,GRAY,T5,W242.8,L484.1,ADH ESIVE	1	PC	SNA
9-3	DA62-01723A	INSULATION-AIR GUIDE	ES-PJT,SSEC,PS FOAM,H73.5	1	PC	SNA
10	DA97-12129A	ASSY COVER EVAP-FRONT	ES-PJT,SSEC	1	PC	SA
10-1	DA63-06674A	COVER EVAP-FRONT	ES-PJT,SSEC,PP,COOL WHITE	1	PC	SNA
10-2	DA62-03432A	INSULATION-COVER EVAP	ES-PJT,SSEC,PS FOAM	1	PC	SNA
10-3	DA61-04022A	PLATE-HEATER EVAP	ES-PJT,SSEC,GI-SGCC,T0.25	1	PC	SNA
10-4	DA61-04024A	PLATE-INS EVAP	ES-PJT,SSEC,HIPS,T1	1	PC	SNA
10-5	DA02-10005A	TAPE-MASKING	FF Models,PAPER,NTR,W25	1	M	SNA
11	DA97-06067E	ASSY COVER-MULTI FRE REAR	ES-PJT,SSEC,GVE,-,-,-,-,-,-,FRE DISPENSER	1	PC	SA
11-1	DA63-04020A	COVER-MULTI FRE REAR	ES-PJT,SSEC,PP,-,-,-,-,-,-	1	PC	SNA
11-2	DA31-00020M	MOTOR BLDC	DREP3030LA,1375 RPM,-,DC12V,-,-,DC SOURCE,3.5W,N-PJT(F),NEW-MODEC,30~40 C	1	PC	SA
11-3	DA63-01808A	GROMMET MOTOR	BLDC,NBR,BLACK,H20	1	PC	SA
11-4	DA63-01146A	GROMMET-MOTOR,REAR	A-TOP,NBR,BLACK,BLDC	1	PC	SA
11-5	DA63-01809A	COVER MOTOR-BLDC	BLDC-NEW,PP,NTR,-,-,-,-,-,BJ-730	1	PC	SA
11-6	DA32-00066H	SENSOR TEMP	-,MT12,-50~80□,5V,-,-,PBA CAP, 502AT or DKST1329 chip,BLU,150	1	PC	SA
11-7	DA31-00052A	FAN PROPELLER	-,N-PJT,ABS,5 WING,Φ145	1	PC	SA
12	DA96-00442E	ASSY EVAP FRE	ES-PJT,09,AL,230V,50HZ,300W	1	PC	SA
12-1	DA59-00372C	EVAP FRE	ES-PJT,09,FIN PIPE,AL,50HZ,300W	1	PC	SNA
12-2	DA61-04026A	PLATE DRAIN	ES-PJT,SSEC,GI	1	PC	SA
12-3	DA47-00279C	HEATER-METAL SHEATH	AC230V,ES, 176.3ohm,300W,INCOLOY840,1645mm,-,Bimetal,35965-9210,MgO	1	PC	SA
12-4	DA32-00024L	SENSOR TEMP	502AT,PX-41C,DKST1329GW,ES-PJT,SSEC,5V,WHT,L250,PVC	1	PC	SA
12-5	DA61-00603A	FIXER SENSOR	n-PJT,PP,T2,NATURAL,HB,BJ750	1	PC	SA

EXPLODED VIEW PART LIST

• Parts List of Freezer

NO	CODE NO	PART NAME	Specification	Quantity	Unit	SA/SNA
12-6	DA47-10148U	THERMO FUSE-ASSY	AC250V,10A,109~110□,S.O.D,ETC(WIRE)	1	PC	SA
12-7	DA61-07451A	PLATE-EVAP HEATER	NW2,Al,T0.7	1	PC	SA
13	DA63-03788B	COVER-FIXER HOUSING	W07,SGCC,T0.4	1	PC	SA
14	DA97-04793B	ASSY RAIL-LOW L	N07-PJT,SSEC,L220,NTR	1	PC	SA
14-1	DA61-03078C	RAIL-LOW LEFT	SSEC,HIPS,NTR	1	PC	SNA
14-2	DA66-00420A	ROLLER-RAIL LOW	N07-PJT,SSEC,POM,NTR	1	PC	SA
15	DA97-04794B	ASSY RAIL-LOW R	N07-PJT,SSEC,L220,NTR	1	PC	SA
15-1	DA61-03079C	RAIL-LOW RIGHT	SSEC,HIPS,NTR	1	PC	SNA
15-2	DA66-00420A	ROLLER-RAIL LOW	N07-PJT,SSEC,POM,NTR	1	PC	SA
16	DA97-06072E	ASSY TRAY-ICE BUCKET	ES,2008GVE,-,-,-,-,SSEC	1	PC	SA
16-1	6002-001204	SCREW-TAPPING	TH,+,-,1,M4,L16,PASS,STS430,-	8	PC	SNA
16-2	DA63-04019A	COVER-ICE BUCKET	ES-PJT,SSEC,PP,-,-,-,-,COOL WHT,-	1	PC	SNA
16-3	DA60-00185A	FASTENER-RING	ES-PJT,SSEC,STS304	1	PC	SNA
16-4	DA60-00186A	FASTENER-WASHER	ES-PJT,SSEC,STS430,T0.5,OD28,ID20	1	PC	SNA
16-5	DA61-03972A	FIXER-AUGER	ES-PJT,SSEC,POM,-,-,AUGER,L13	1	PC	SNA
16-6	DA63-03935A	COVER-CRUSHER DISP	ES-PJT,SSEC,HIPS,W145.9,L170.7,COOL WHITE	1	PC	SNA
16-7	DA61-03864A	GUIDE-ICE DISPENSER	ES-PJT,SSEC,HIPS,-,-,-,NTR,-	1	PC	SNA
16-8	DA61-03969A	FIXER-SPIRAL	ES-PJT,SSEC,STS304,T1,PIN	1	PC	SNA
16-9	DA61-03865A	FIXER-BLADE	ES-PJT,SSEC,POM,-,NTR,-	1	PC	SNA
16-10	DA31-00205A	BLADE-MOVING C	ES-PJT,SSEC,STS304,T2.0	1	PC	SNA
16-11	DA31-00206A	BLADE-MOVING B	ES-PJT,SSEC,STS304,T2.0	1	PC	SNA
16-12	DA31-00207A	BLADE-MOVING A	ES-PJT,SSEC,STS304,T2.0	1	PC	SNA
16-13	DA61-04262A	SUPPORT-BLADE B	ES-PJT,SSEC,POM,-,-,NTR,-	2	PC	SNA
16-14	DA61-04261A	SUPPORT-BLADE A	ES-PJT,SSEC,POM,-,-,NTR,-	2	PC	SNA
16-15	DA31-00209A	BLADE-STATIONARY DISP OUT	ES-PJT,SSEC,STS304,T2.0	1	PC	SNA
16-16	DA31-00208A	BLADE-STATIONARY DISP IN	ES-PJT,SSEC,STS304,T2.0	1	PC	SNA
16-17	DA65-00049A	CLAMPER CORE-HELIX	ES-PJT,SSEC,POM+STS304,INSERT	1	PC	SNA
16-18	DA63-03934A	TRAY ICE-BUCKET	ES-PJT,SSEC,PP,NATURAL	1	PC	SNA
16-19	DA66-00529A	LEVER-CUBE	ES-PJT,SSEC,MSWR10,-,-,-,-,-	1	PC	SNA
16-20	DA61-03947A	SPRING ETC-DISPENSE	ES-PJT,SSEC,STS304,OD0.8	1	PC	SNA
17	DA97-08802K	ASSY CASE AUGER MOTOR	ES,LED,GVE,2EA,220V~240V/50HZ	1	PC	SA
17-1	6002-000213	SCREW-TAPPING	TH,+,-,1,M4,L12,ZPC(WHT),SWRCH18A	3	PC	SNA
17-2	DA31-00105F	MOTOR GEARED AC AUGER	ISG3240SSH-1 / ORG-4004P2-1,220/240V,15RPM,1.0A,T40, Round, T/P 80/55□	1	PC	SA
17-4	DA60-00001B	SCREW-SPECIAL	HEX,L6.3,PASS,STS304	3	PC	SNA
17-5	DA60-10130B	SCREW-TAPPING	TH,-,-,M4.2,L13,ZPC(WHT),SWRCH18A,-,-	1	PC	SA
17-6	DA61-03867A	BUSH-SOLENOID	ES-PJT,SSEC,POM,SC-93438R,WHITE	1	PC	SNA
17-7	DA61-03868A	SLIDER-SOLENOID DISP	ES-PJT,SSEC,POM,-,-,NTR,-	1	PC	SNA
17-8	DA61-03869C	CASE-AUGER MOTOR	ES-PJT,SSEC,PP,NATURAL	1	PC	SA
17-9	DA61-03946A	SPRING ETC-SOLENOID	ES-PJT,SSEC,STS304,ID7.5,OD0.7,L30.1	1	PC	SNA
17-10	DA61-03950A	FIXER-NUT	ES-PJT,SSEC,STS420+SK5,CLIP	1	PC	SNA
17-11	DA61-03971A	FIXER-SPRING A	ES-PJT,SSEC,STS304,-,-,L22,PIN	1	PC	SNA
17-12	DA61-03971B	FIXER-SPRING B	ES-PJT,SSEC,STS304,-,-,L16,PIN	1	PC	SNA

EXPLODED VIEW PART LIST

Fridge

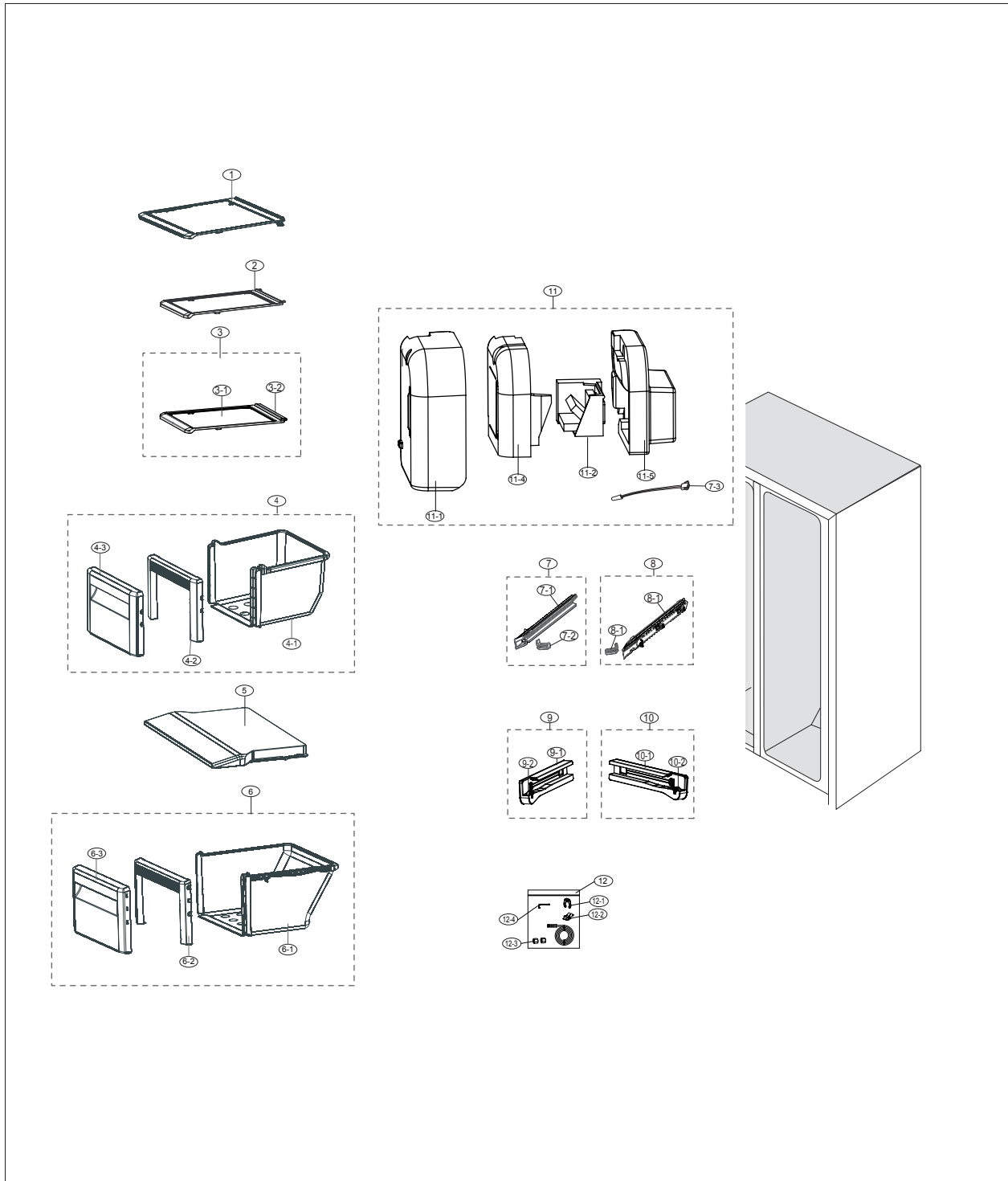

EXPLODED VIEW PART LIST

• Parts List of Fridge

NO	CODE NO	PART NAME	Specification	Quantity	Unit	SA/SNA
1	DA67-03366A	SHELF REF-HIGH	ES-PJT,SSEC,PP+GLASS,COOL WHITE	3	PC	SA
2	DA67-03365A	SHELF REF-LOW	ES-PJT,SSEC,PP+GLASS,COOL WHITE	1	PC	SA
3	DA97-12318A	ASSY SHELF REF-LOW	ES-PJT,SSEC,PP+GLASS	1	PC	SA
3-1	DA67-03365A	SHELF REF-LOW	ES-PJT,SSEC,PP+GLASS,COOL WHITE	1	PC	SA
3-2	DA67-03196B	SHELF-TRIM	ES-PJT,SSEC,PVC,COOL WHITE,PVC	1	PC	SNA
4	DA97-06063B	ASSY CASE VEG-UP	ES-PJT,SSEC	1	PC	SA
4-1	DA61-04037A	CASE-VEG HIGH	ES-PJT,SSEC,PP,COOL WHITE,W380.3,L440.8	1	PC	SNA
4-2	DA63-04036A	COVER VEG-FRONT HIGH B	ES-PJT,SSEC,HIPS,-,W187,L434,-,-,COOL WHT,-	1	PC	SNA
4-3	DA63-04037C	COVER VEG-FRONT UP A	ES-PJT,SSEC,GPPS,HB,-,PG383M,Transparency,BLUE	1	PC	SNA
5	DA63-04053A	COVER VEG-HIGH	ES-PJT,SSEC,HIPS,W343,L439.8,COOL WHT	1	PC	SA
6	DA97-06064B	ASSY CASE VEG-LOW	ES-PJT,SSEC	1	PC	SA
6-1	DA61-04036A	CASE-VEG LOW	ES-PJT,SSEC,PP,W366,L429,COOL WHT	1	PC	SNA
6-2	DA63-04029A	COVER VEG-FRONT LOW B	ES,HIPS,COOL WHITE	1	PC	SNA
6-3	DA63-04031B	COVER VEG-FRONT LOW A	ES-PJT,SSEC,GPPS,HB,-,PG383M,Transparency,BLUE	1	PC	SNA
7	DA97-01291B	ASSY RAIL-BASKET L(ET)	ES-PJT,NATURAL	1	PC	SA
7-1	DA61-00044C	RAIL-BASKET L(ET)	ET-PJT,HIPS,NATURAL	1	PC	SNA
7-2	DA63-05275A	GROMMET-RAIL	ES-PJT,SSEC,PA6,SC-93437R	1	PC	SNA
8	DA97-01292B	ASSY RAIL-BASKET R(ET)	ES-PJT,NATURAL	1	PC	SA
8-1	DA61-00045C	RAIL-BASKET R(ET)	ET-PJT,HIPS,NATURAL,S834S1	1	PC	SNA
8-2	DA63-05275A	GROMMET-RAIL	ES-PJT,SSEC,PA6,SC-93437R	1	PC	SNA
9	DA97-04793B	ASSY RAIL-LOW L	N07-PJT,SSEC,L220,NTR	1	PC	SA
9-1	DA61-03078C	RAIL-LOW LEFT	SSEC,HIPS,NTR	1	PC	SNA
9-2	DA66-00420A	ROLLER-RAIL LOW	N07-PJT,SSEC,POM,NTR	1	PC	SA
10	DA97-04794B	ASSY RAIL-LOW R	N07-PJT,SSEC,L220,NTR	1	PC	SA
10-1	DA61-03079C	RAIL-LOW RIGHT	SSEC,HIPS,NTR	1	PC	SNA
10-2	DA66-00420A	ROLLER-RAIL LOW	N07-PJT,SSEC,POM,NTR	1	PC	SA
11	DA97-12132B	ASSY COVER DAMPER-REF	ES-PJT,COOL WHITE	1	PC	SA
11-1	DA63-06675A	COVER DAMPER-REF	ES-PJT,SSEC,11,PP,COOL WHT	1	PC	SNA
11-2	DA31-00071C	MOTOR DC-DAMPER	NSBY001TD1/FBZA-1750-15A/DU25-072,DC 12V,MAX 60mA,7.2W,HEATER Type	1	PC	SC
11-3	DA32-00024V	SENSOR TEMP	NW2,5V,F-DEF-SENSOR,YELLOW,250	1	PC	SA
11-4	DA62-03433A	INSULATION-DAMPER REF UP	ES-PJT,SSEC,PS FOAM	1	PC	SNA
11-5	DA62-03434A	INSULATION-DAMPER REF LOW	ES-PJT,SSEC,PS FOAM	1	PC	SA
12	DA97-11752A	ASSY INSTALL-FILTER	GUGGENHEIM	1	PC	SA
12-1	DA61-04522A	CLIP-FITTING LOCK	AW,POM	1	PC	SNA
12-2	DA63-04744A	COVER-CHECK VALVE	HM,PP,HB,GRAY,CNTK-P-101,Recycle	1	PC	SA
12-4	DA80-00002F	WRENCH-SPANNER	AW3,SM45C,Zn PLATING	1	PC	SA
12-5	DA74-00070B	VALVE-FITTING NUT	A-TOP,C3604,gold	2	PC	SA
13	DA29-10105J	FILTER-WATER	SBS ALL,-,-	1	PC	SA

EXPLODED VIEW PART LIST

• Parts List of Cabinet

NO	CODE NO	PART NAME	Specification	Quantity	Unit	SA/SNA
1	DA97-14174L	ASSY COVER HINGE-UP LEFT	ES 17FaceLift,I BLACK,BK0044,ASSY	1	PC	SA
1-1	DA63-03958Q	COVER HINGE-UP LEFT	ES 17FaceLift,ABS,T2.5,I BLACK,BK0044	1	PC	SA
1-2	DA34-00043J	SWITCH REED	UL1007 AWG 22,50mm	1	PC	SA
2	DA61-03933A	HINGE-UPP L	ES-PJT,SSEC,SHP1,T3.0,-,-,BLACK,-,-	1	PC	SA
3	DA61-03932A	HINGE-UPP R	ES-PJT,SSEC,SHP1,T3.0,-,-,BLACK,-,-	1	PC	SA
4	DA97-14175L	ASSY COVER HINGE-UP RIGHT	ES 17FaceLift,I BLACK,BK0044,ASSY	1	PC	SA
4-1	DA63-03959Q	COVER HINGE-UP RIGHT	ES 17FaceLift,ABS,T2.5,I BLACK,BK0044	1	PC	SA
4-2	DA34-00043J	SWITCH REED	UL1007 AWG 22,50mm	1	PC	SA
5	DA63-01077C	COVER-PURIFIER	ES,2008GVE,HIPS,NTR	1	PC	SA
6	DA97-05765A	ASSY HINGE LOW-L	ES-PJT,SSEC,T4.5,W80.4,L57.8,-,-,-	1	PC	SNA
6-1	6003-001435	SCREW-TAPTYPE	HWH,+S,M5,L12.7,ZPC2(WHT),SWCH22AKILLED STEEL(1018K)	1	PC	SNA
6-2	DA66-00343A	CAM-RISER	USP05(ATOP,ET),PA66,BLACK	1	PC	SNA
6-3	DA61-03941A	HINGE-LOW L	ES-PJT,SSEC,CR-SPCC,T4.5,B	1	PC	SC
7	DA97-01763A	ASSY HINGE LOW R	A-TOP,BASIC,10.5 Gasket,-,-,-,-	1	PC	SC
7-1	6003-001435	SCREW-TAPTYPE	HWH,+S,M5,L12.7,ZPC2(WHT),SWCH22AKILLED STEEL(1018K)	1	PC	SNA
7-2	6011-001442	BOLT-SOCKET	M8,L13.4,ZPC(BLK),SCM435,4mm,FE-FZB	1	PC	SNA
7-3	6021-001125	NUT-HEXAGON	3,M8,ZPC(WHT),SWCH10A	1	PC	SNA
7-4	DA61-01608A	HINGE-LOW REF	ES-PJT,SSEC,CR-SPCC,T4.5,B,A-TOP	1	PC	SNA
7-5	DA66-00343A	CAM-RISER	USP05(ATOP,ET),PA66,BLACK	1	PC	SNA
8	DA61-30102D	FOOT-FRONT	ES,PP,BLACK,0103-002776,N	2	PC	SA
9	DA61-03151C	BRACKET HINGE-LOW	ES-PJT,AI	1	PC	SNA
10	DA60-10123C	BOLT-HEX	M6,L24,ZPC(WHT),SWRCH18A,HWH Head, 1018K	6	PC	SA
11	DA41-00675J	ASSY LAMP LED	2,CEM-1,110*20,WHITE,SMW250-03G,120mA~160mA,DC12V,MIN 45lx	1	PC	SA
12	DA63-05460B	COVER LAMP	SUPER STAR,GPSS,W35,L145,transparent	1	PC	SA
13	DA97-08671B	ASSY CASE LAMP	CC-PJT,ASSY NTR	1	PC	SA
14	DA63-09312D	COVER LEG-FRONT	PP,T2.5,I BLACK	1	PC	SNA
16	DA97-05772C	ASSY CHASSIS-COMP	ES-PJT,SSEC,GVE,-,T1.2,-,-,-,-	1	PC	SA
16-1	DA60-90146A	PIN-CASTER	SR-289-429,MSWR,L38,ZPC2	2	PC	SNA
16-2	DA61-00190A	CASTER	SR-32,PP,-,-,-,-,WHIRLPOOL	2	PC	SNA
16-3	DA64-02381C	CHASSIS COMP	ES-PJT,SSEC,SGCC,T1,-,GVE,HGI	1	PC	SNA
17	DA97-17854D	ASSY TRAY DRAIN WATER	ES,PFC-B,ASSY TRAY DRAIN WATER	1	PC	SNA
17-1	DA63-07323A	GROMMET-IMMERSION PIPE B	ROMANEE CONTI,NBR,BLACK	4	PC	SA
17-2	DA97-17855B	ASSY CONDENSER-MAIN	PFC B,AL(LA+CE),LOUVER FIN	1	PC	SA
17-3	DA97-19035A	ASSY COVER-TRAY UP	RN7000H,PFC	1	PC	SA
17-4	DA97-19148A	ASSY TRAY DRAIN WATER	ES 17FaceLift,ASSY,PFC B	1	PC	SA
17-4-1	DA60-10130B	SCREW-TAPPING	TH,-,-,M4.2,L13,ZPC(WHT),SWRCH18A,-,-	1	PC	SA
17-4-2	DA63-09068A	TRAY DRAIN-WATER	PP,BLACK,SCRAP PP	1	PC	SA
17-4-3-1	DA61-20128A	SPRING ETC-FAN	STS304,PI8.8,ID7.8,OD9.8,L5.0,FD	2	PC	SA
17-4-3-2	DA31-00278C	MOTOR BLDC FAN	ARCS2088LA,1120,12V,0.14,1.7W,NK-V3,-10~70	1	PC	SNA
18	DA60-10124A	BOLT-HEX	M6,L16,ZPC(WHT),SWRCH18A,HWH Head	1	PC	SA

EXPLODED VIEW PART LIST

• Parts List of Cabinet

NO	CODE NO	PART NAME	Specification	Quantity	Unit	SA/SNA
19	DA97-15180D	ASSY CASE PCB-MAIN	RS50N3503S8/PE,GRY,ENV2_AL	1	PC	SNA
19-1	DA61-03917A	CASE PCB-PANEL	ES,PP,MANHATTAN SILVER, V-0	1	PC	SA
19-2	DA92-01053D	ASSY PCB MAIN	ASSY PCB MAIN,es face lift,197*197mm,Y,110-240V,12V,25.7W,FR-1,Ice Maker,INV,R600a,STANDARD	1	PC	SA
19-3	DA27-00027G	COIL FILTER	14mH,82*60,5A,0.68uF,1500pF,220V,SURGE_ABSORBER	1	PC	SNA
19-4	DA92-00763H	ASSY PCB INVERTER	INVERTER,Superstar,163*98.5,Y,220V,15V, 5V,F3_AL,-	1	PC	SNA
20	DA97-15326A	ASSY COVER PCB-PANEL	super star,ASSY	1	PC	SA
20-1	DA63-03963A	COVER PCB-PANEL	ES-PJT,SSEC,SBHG1,T0.4,W264.1,L520.1,-,-,-,-	1	PC	SA
21	DA97-06758F	ASSY COVER COMP	ES10-PJT,SSEC,T0.4,INVERTER	1	PC	SA
23	DA60-00280A	FITTING-LOKRING 33	SUM23,33, 11SMnPb30K	1	PC	SA
24	DA60-00281A	FITTING LOKRING	SUM23,ID5.02,11SMnPb30K,St 56	1	PC	SNA
25	DA97-11684A	ASSY PIPE CONNECT-SUCTION	NW2-PJT,SSEC,INVERTER,C1220T	1	PC	SA
26	DA73-00050G	PIPE-CONN	Cu,OD6.35,T0.6	1	PC	SA
27	NF34J9151ANSJ3	CMP,COMP,REFRIGERATOR,R-600A	0	1	PC	-
28	6011-004061	BOLT-HEX	M6,L43.6,SWRCH10A	4	PC	SA
29	DA63-02617A	GROMMET COMP	USP05,EPDM,OD27.0,BLACK	4	PC	SA
31	DA39-20389L	ASSY WIRE HARNESS-EARTH	EARTH,ALL,,,,,FREE VOLT,UL+IEC,UL,,,,,150mm,1,ST710489-3*2,,,,,*****	1	PC	SA
32	DA62-01469H	DRYER	C1220T-H,115,SINGLE MOUTH	1	PC	SA
33	DA97-19346A	ASSY CAP DRAIN	ES 17'FaceLift,ASSY	1	PC	SA
33-1	DA67-01301A	CAP-DRAIN	AW4,HIPS,HB,S834S1,NATURAL	1	PC	SA
34	3903-001025	CBF-POWER CORD	AT,UK,GB3F,3C,250V,13A,Black,2000,20/100/100/200,H05VV-F 0.75mm^2,BSI/PSB,Y,N,Y,N,Y	1	PC	SA
35	DA99-03667A	ASSY CUSHION BOTTOM	ES-PJT,L958,W761,H161	1	PC	SA
36	DA97-16103A	ASSY PIPE SUCTION	ES,09	1	PC	SNA
38	DA60-00259B	FITTING TUBE	TUBE FITTING B,PP,1/4'-5/16'	1	PC	SA
39	DA61-03872C	FIXER HOSE-REAR FRAME	ES-PJT,VE,HIPS,NTR	1	PC	SA
40	DA97-02682A	ASSY VALVE WATER	EPEL,-,-,-,-	1	PC	SA
41	DA97-05786B	ASSY TANK WATER	ES-PJT,SSEC,-,-,-,-,-,FRE DISPENSER	1	PC	SA
40-1	DA62-00914A	VALVE WATER	AC220-240V,-,2WAY,#187+250,1,2,NO	2	PC	SA
42	DA97-05803A	ASSY PIPE-WATER FRE	ES-PJT,SSEC,230V/10W	1	PC	SA
42-1	DA47-00270A	HEATER-WATER PIPE	AC230V,ES, 8817ohm,6W,PVC,665mm,380mm,N on,35151-0210,-	1	PC	SA
42-2	DA63-03946A	GROMMET-WATER PIPE FILL IN	ES-PJT,SSEC,SI,ICE MAKER	1	PC	SNA
42-3	DA62-01680A	SEAL-PIPE WATER	ES-PJT,SSEC,PE FOAM,GRAY,T3,DISP,ADHESIVE	1	PC	SNA
42-4	DA62-01683A	PIPE-AL	ES-PJT,SSEC,AL,-	1	PC	SNA
42-5	DA62-01672A	PIPE-WATER FRE A	ES-PJT,SSEC,PP,ID6.5,OD11.1	1	PC	SNA
42-6	DA62-01368A	PIPE-WATER LINE	LLDPE,WHITE,I,D4.2, O.D6.35	1	M	SNA
42-7	DA62-01670A	SEAL-TUBE	ES-PJT,SSEC,PE FOAM,GRAY,T5,ID22,L144,-,PIPE WATER	1	PC	SNA
42-8	DA61-03903A	FIXER VALVE WATER-B	ES-PJT,SSEC,PA66,NTR,OD6.1,L10,ID3.3	1	PC	SNA
43	DA32-00034B	SENSOR HUMIDITY	DA32-00034B,SHT20P,5V,0 to 100%,REF	1	PC	SA
44	DA72-00218A	SEAL BUTYL RUBBER	RUBBER,BLACK,T3,W50,L80,-	1	PC	SA
45	DA60-90124A	RIVET	MSWR,L56	1	PC	SA
46	DA61-02514B	CASTER-FRONT	RF5500,PP	1	PC	SA

EXPLODED VIEW PART LIST

Freezer Door

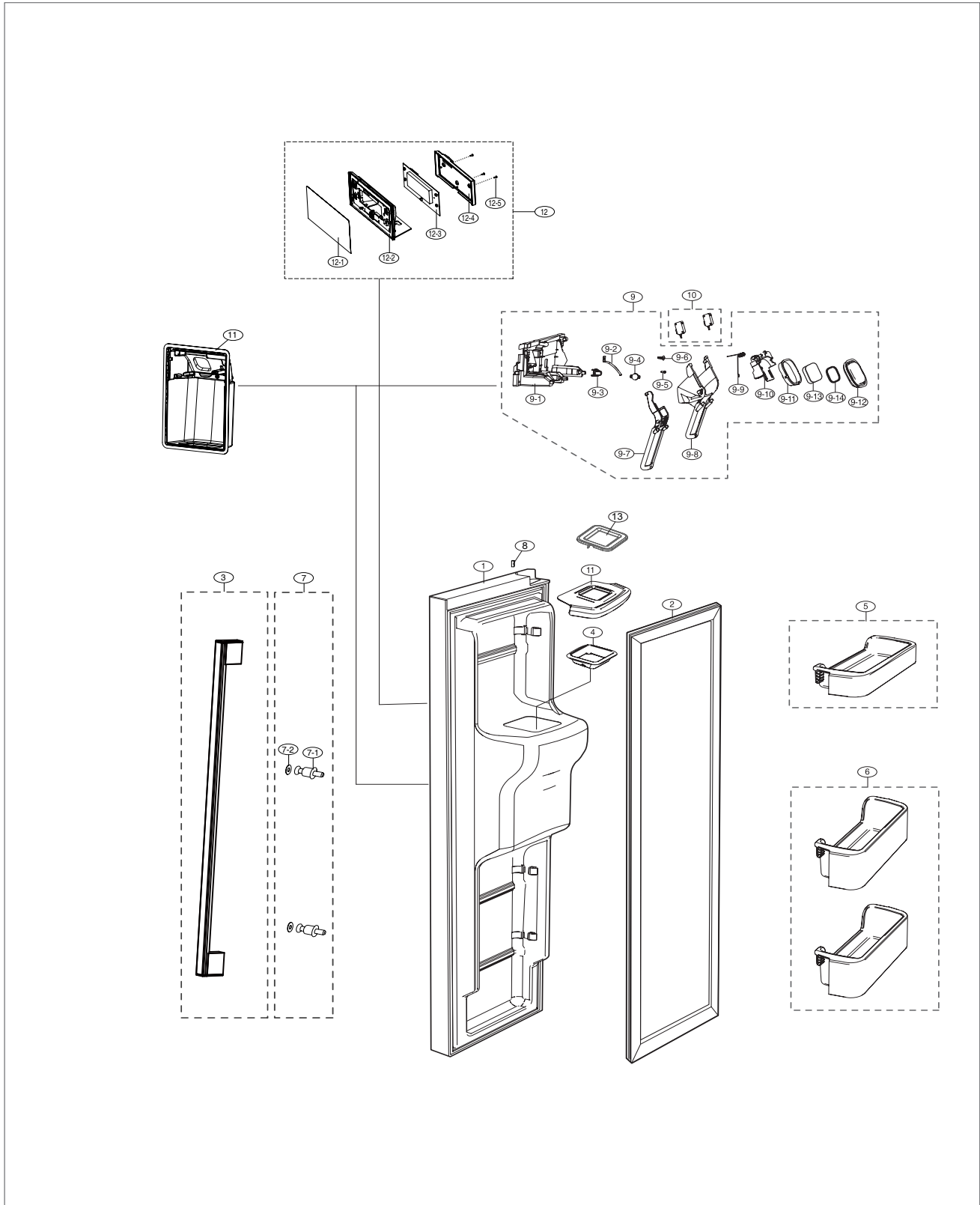

EXPLODED VIEW PART LIST

• Parts List of Freezer Door

NO	CODE NO	PART NAME	Specification	Quantity	Unit	SA/SNA
1	DA94-04219R	ASSY DOOR FOAM FRE	RS50N3403BC	1	PC	SA
2	DA97-19336A	ASSY GASKET-FRE	ES 17'Facelift,BLACK	1	PC	SA
3	DA97-11103M	ASSY HANDLE-REF	ES 17' facelift,Mature Black	2	PC	SA
4	DA67-01865A	CAP-CHUTE ICE	ES-PJT,SSEC,ABS,T1.8,W106,L119,HB,HG-0760GP,COOL WHITE,DISPENSER	1	PC	SA
5	DA97-07426B	ASSY GUARD-FRE UP	ES09-PJT,GPPS+HIPS	1	PC	SA
6	DA97-07427D	ASSY GUARD-FRE LOW	ES10,ES GLASS,GPPS+HIPS	2	PC	SA
7	DA61-06887A	FIXER-HANDLE	ES10,N10-PJT,SSEC,POM,NTR	2	PC	SA
8	DA61-03949A	MAGNET	ES-PJT,SSEC,FERRITE,1600Gauss	1	PC	SA
9	DA97-19135A	ASSY CASE ICE ROUTE	ES 17' facelift,2 LEVER	1	PC	SA
9-1	DA61-12979A	CASE LEVER DISPENSER	ES-PJT,HIPS,T2.5,NATURAL	1	PC	SNA
9-2	DA61-03928A	SPRING ETC-LEVER DISP WATER	ES-PJT,SSEC,STS304,T0.6,W11	1	PC	SNA
9-3	DA61-03909A	BRACKET-OIL DAMPER	ES-PJT,SSEC,ABS,L16.8,COOL WHT	1	PC	SNA
9-4	DA61-01869A	OIL DAMPER	AD,PC+POM, 120g/Cm, , OD15	1	PC	SNA
9-5	6002-000630	SCREW-TAPPING	PH,+ ,NO,2S,M3,L8,ZPC(WHT),SWRCH18A	1	PC	SNA
9-6	DA60-10130B	SCREW-TAPPING	TH,- ,M4.2,L13,ZPC(WHT),SWRCH18A,- ,	1	PC	SA
9-7	DA66-01218A	LEVER CASE DISPENSER	SUPERSTAR,SAN,182,59,110,TP BLUE	1	PC	SNA
9-8	DA66-01219A	LEVER CASE DISPENSER	SUPERSTAR,SAN,174,59,110,TP BLUE	1	PC	SNA
9-9	DA61-03929A	SPRING ETC-COVER ICE ROUTE	ES-PJT,SSEC,STS304,OD1.0	1	PC	SNA
9-10	DA63-03950B	COVER-ICE ROUTE A	ES-PJT,SSEC,ABS,-,-,-,-,-,BLACK,-	1	PC	SNA
9-11	DA63-03939B	COVER-ICE ROUTE B	ES-PJT,SSEC,HIPS,-,-,-,-,-,NTR,VE	1	PC	SNA
9-12	DA63-03941A	GASKET-COVER ICE ROUTE	ES-PJT,SSEC,SI,T1.5,W79.3,L79.8,BLACK	1	PC	SNA
9-13	DA62-00058E	SEAL-COVER ICE,ROUTE	AD,LEX FOAM,WHITE,T12,64,64	1	PC	SA
9-14	DA62-00058F	SEAL-COVER ICE,ROUTE	AD,LEX FOAM,WHITE,T5,54.5,54.5	1	PC	SA
10	DA34-00011B	SWITCH-MICRO	125/250V,16A,200gf,SPST-NO	2	PC	SA
11	DA61-03904M	CASE DISPENSER	ES 17' facelift,ABS,T2.5,I BLACK	1	PC	SNA
12	DA97-15850C	ASSY COVER DISPENSER	ES 17' facelift,BLACK,D-OPTION,VACATION	1	PC	SA
12-1	DA64-04878C	INLAY CONTROL	ES 17' facelift,PC,T0.38,W123.8,L240.6,BLACK, D-OPTION,VACATION	1	PC	SNA
12-2	DA63-08190B	COVER DISPLAY	ES 17' facelift,ABS,T2.5,HB,I BLACK , D-OPTION	1	PC	SNA
12-3	DA41-00533H	ASSY MODULE	A S S Y P C B K I T L E D , E S - P J T , E N , W 8 8 , T 1 . 6 , L 2 0 0 , F R E DISPENSER,VOCATION,Ice Blue	1	PC	SA
12-4	DA61-04100A	CASE-PBA DISPLAY	ES - P J T , S S E C , P P , W 9 4 . 2 , L 2 0 7 , N T R , F R E DISPENSER	1	PC	SNA
12-5	6002-000630	SCREW-TAPPING	PH,+ ,NO,2S,M3,L8,ZPC(WHT),SWRCH18A	3	PC	SNA
13	DA63-07929A	GUARD-SUB	ES-PJT,ABS,COOL WHITE	1	PC	SA

EXPLODED VIEW PART LIST

Fridge Door

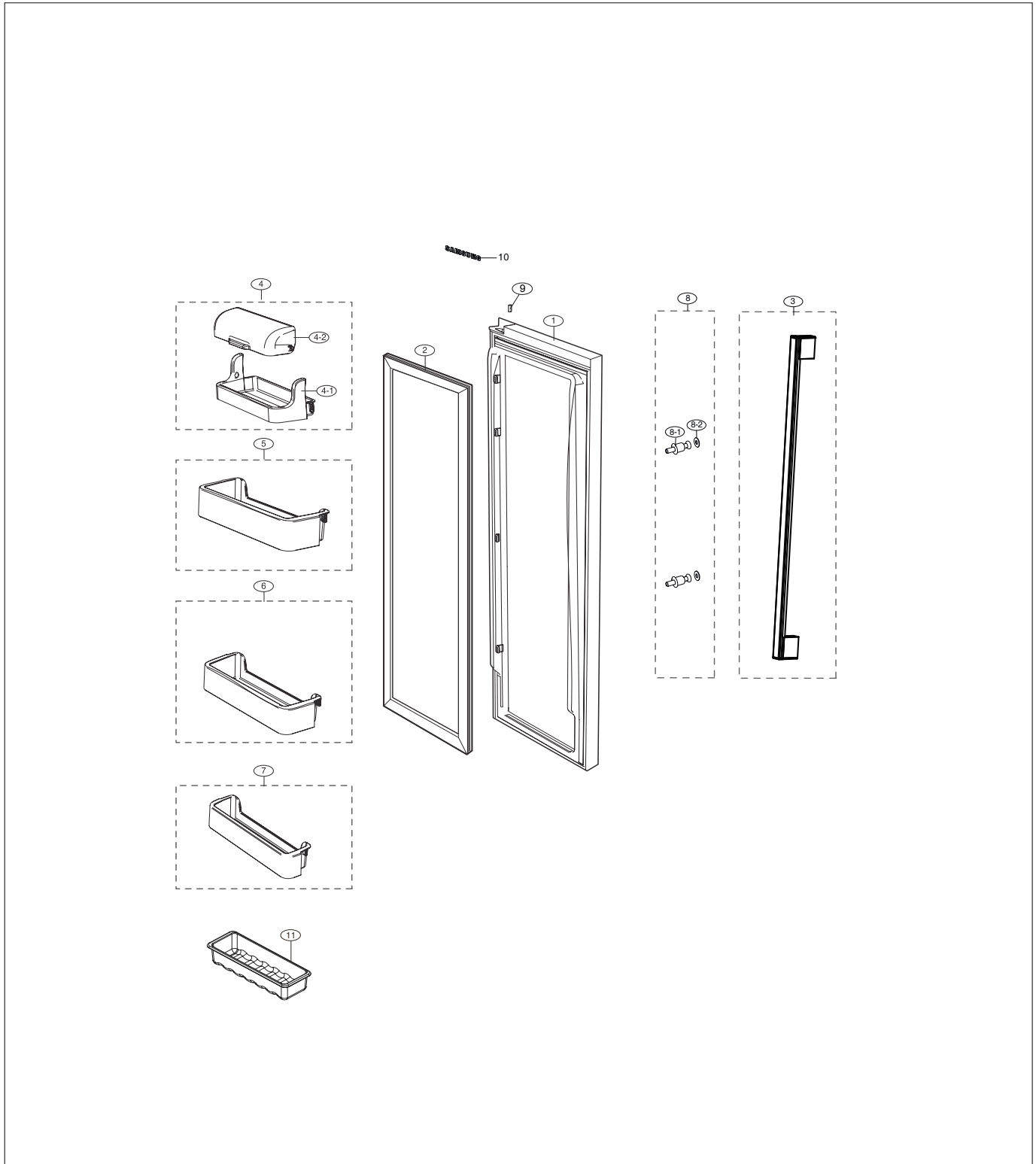

EXPLODED VIEW PART LIST

• Parts List of Fridge Door

NO	CODE NO	PART NAME	Specification	Quantity	Unit	SA/SNA
1	DA94-04218Q	ASSY DOOR FOAM REF	RS50N3403BC	1	PC	SA
2	DA97-19335A	ASSY GASKET-REF	ES 17'FaceLift,BLACK	1	PC	SA
3	DA97-11103M	ASSY HANDLE-REF	ES 17' facelift,Mature Black	1	PC	SA
4	DA97-07428B	ASSY GUARD DAIRY	ES09-PJT,SSEC	1	PC	SA
5	DA97-07429B	ASSY GUARD-REF UP	ES09-PJT,GPPS+HIPS	1	PC	SA
6	DA97-07430B	ASSY GUARD-REF MIDDLE	ES09-PJT,GPPS+HIPS	1	PC	SA
7	DA97-07431B	ASSY GUARD-REF LOW	ES09-PJT,GPPS+HIPS	1	PC	SA
8	DA61-06887A	FIXER-HANDLE	ES10,N10-PJT,SSEC,POM,NTR	4	PC	SA
9	DA61-03949A	MAGNET	ES-PJT,SSEC,FERRITE,1600Gauss	1	PC	SA
10	DA64-04021A	MASCOT	ALL,Ni,T0.06,L90	1	PC	SA
11	DA63-06420A	TRAY EGG	NW2-PJT,SSEC,GPPS,-,-,TP BLUE	1	PC	SA