

2. Exploded View

2-1. Freezer Compartment

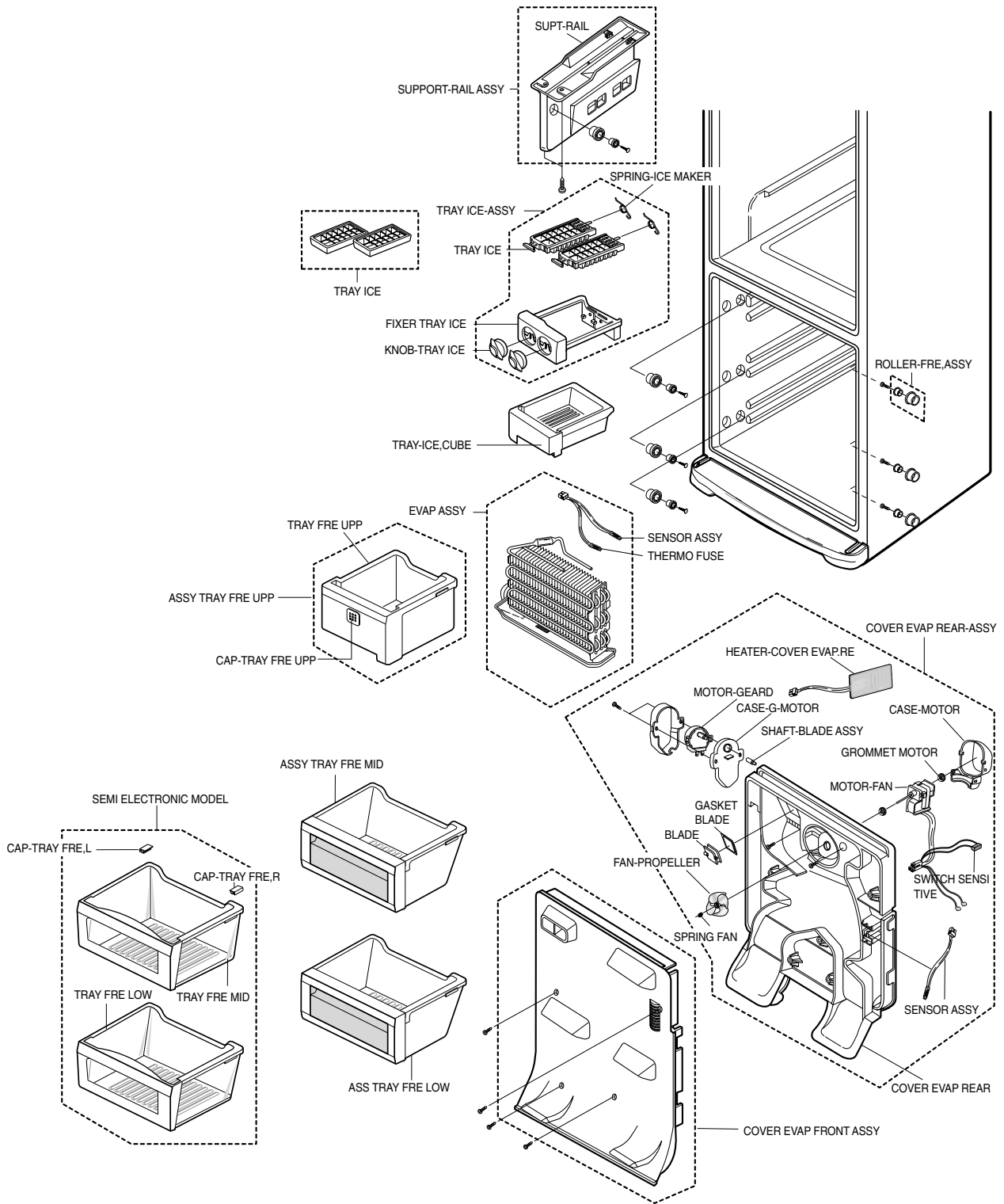

■ Freezer List

NO	CODE-NO	ITEM	SPECIFICATION	OPTION		
				RL36/39E	RL39W	RL36/39S
1	DA63-00395C	COVER EVAP-FRONT,ASSY	PP,T2.0,TWIST	●	●	
	DA63-00395D		PP,T2.0,SEMI			●
	DA63-00395E		PP(NTR),T2.0,TWIST	●	●	
	DA63-00395F		PP(NTR),T2.0,SEMI			●
2	DA66-00093A	ROLLER-FRE-ASSY	POM,SR-35	●	●	●
3	DA97-01392A	ASSY TRAY-FRE,LOW	PREMIUM	●	●	
4	DA97-01457A	ASSY TRAY-FRE,LOW	SEMI			●
5	DA97-01393A	ASSY TRAY-FRE,MID	PREMIUM	●	●	
6	DA97-01456A	ASSY TRAY-FRE,MID	SEMI			●
7	DA97-01394A	ASSY TRAY-FRE,UPP	HIPS	●	●	
8	DA97-01401A	ASSY TRAY-ICE	PREMIUM	●	●	
9	DA97-01434A	ASSY-SUPT RAIL	PREMIUM	●	●	
10	DA63-01708A	TRAY ICE CUBE	HIPS	●	●	
11	DA96-00024A	ASSY-VAP	127V,310W	●	●	●
	DA96-00024B		240V,310W	●	●	●
	DA96-00024C		220V,310W	●	●	●
12	DA32-10105Q	SENSOR ASSY	502AT,-10~35,5V	●	●	●
13	DA47-10162F	THERMO FUSE	250V,10A	●	●	●
14	DA63-00396R	COVER EVAP-REAR,ASSY	230~234V/50Hz	●	●	●
	DA63-00396S		220V/50Hz	●	●	●
	DA97-00150A		127V/60Hz	●	●	●
15	DA31-00002P	MOTOR FAN	230~240V/50Hz	●	●	●
	DA31-00002U		220V/50Hz	●	●	●
	DA31-00002X		127V/60Hz	●	●	●
16	DA31-00019A	FAN-PROPELLER	NTR	●	●	●
17	DA31-00026A	BLADE	PC,NTR,SR-32,35	●	●	●
18	DA31-10107C	MOTOR GEAR	M2LA49Z,220~240V	●	●	●
	DA31-10107B		M2BC59ZR12,110V	●	●	●
19	DA34-10125B	SWITCH SENSITIVE	5V,Black	●	●	●
20	DA47-00056A	HEATER-COVER EVAP.RE	240V,7W	●	●	●
	DA47-00056B		220V,7W	●	●	●
	DA47-00056C		127V,7W	●	●	●
21	DA61-00081A	CASE-MOTOR	PP,NTR	●	●	●
22	DA61-00117A	CASE-G-MOTOR	PP,NTR	●	●	●
23	DA61-20128A	SPRING ETC-FAN	STS27,PI7.8,ID1.0	●	●	●
24	DA63-00237A	COVER-EVAP REAR	PP	●	●	●
25	DA63-00359A	GASKET-BLADE	SILICON,NTR	●	●	●
26	DA66-00095A	SHAFT-BLADE ASSY	POM	●	●	●
27	DA63-00771A	GROMMET-FAN MOTOR	NBR,BLACK	●	●	●
28	DA70-00222B	PLATE-COVER RE	SAZCC,T0.4	●	●	●

2-2. Refrigerator Compartment

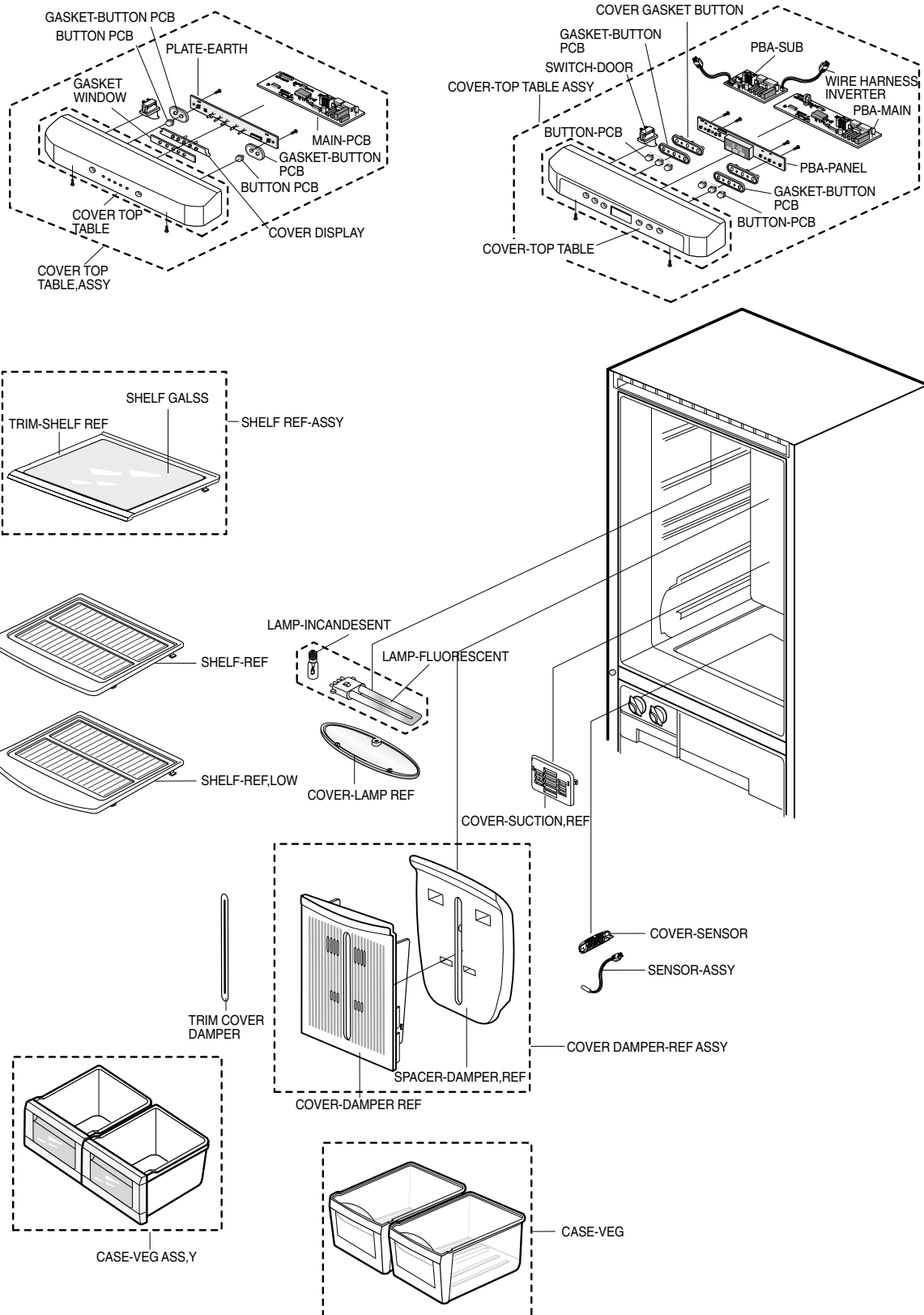

■ Refrigerator List

NO	CODE-NO	ITEM	SPECIFICATION	OPTION		
				RL36/39E	RL39W	RL36/39S
1	DA97-01389A	ASSY COVER DAMPER-REF	SC-97527R	●	●	●
2	DA64-00951A	TRIM-COVER DAMPER	HIPS	●	●	●
3	DA97-01387A	ASSY CASE VEG	PREMIUM	●	●	
4	DA61-01314A	CASE VEG	GPPS(HF-2660),NTR			●
5	DA97-01409A	ASSY SHELF REF	GLASS,3-PC,VEG	●	●	
6	DA67-00207B	SHELF REF	GPPS(HF-2660),NTR			●
7	DA67-00206B	SHELF REF,LOW	GPPS(HF-2660),NTR			●
8	DA97-01385A	ASSY COVER-TOP, TABLE	PREMIUM,SNOW WHITE	●	●	
	DA97-01385B		PREMIUM,MIST SILVER	●	●	
9	DA34-00015C	SWITCH DOOR	250VAC,0.24A	●	●	
10	DA39-00119C	WIRE HARNESS-D00R	240V	●	●	
11	DA41-00018C	PBA MAIN	FR-1,250*55	●	●	
12	DA41-00172A	PBA-DISPLAY	258*30	●	●	
13	DA63-01732A	COVER TOP-TABLE	ABS(VT-0823),SNOW WHITE	●	●	
	DA63-01732B		ABS(VT-0823),MIST SILVER	●	●	
14	DA63-01734A	COVER DISPLAY	ABS	●	●	
15	DA63-01755A	GASKET-BUTTON,PCB	SILICONE,BLACK	●	●	
16	DA63-01776A	COVER-GASKET BUTTON	HIPS(HG-1760SF)	●	●	
17	DA64-00963A	BUTTON-PCB	ABS(HG-0760),WHITE	●	●	
18	DA97-01384A	ASSY COVER-TOP, TABLE	SEMI,SNOW WHITE			●
	DA97-01384B		SEMI,MIST SILVER			●
19	DA34-00015C	SWITCH DOOR	250VAC,0.24A			●
20	DA39-00119C	WIRE HARNESS-D00R	240V			●
21	DA41-00042C	PBA MAIN	CABINET,FR-1,248*55			●
22	DA41-00081A	PBA PANEL ASSY	SEMI			●
23	DA41-00043A	PBA PANEL	SEMI			●
24	DA70-00208A	PLATE EARTH	SBHG1,T0.8			●
25	DA63-01754A	COVER TOP-TABLE	ABS,SNOW WHITE			●
	DA63-01754B		ABS,MIST SILVER			●
26	DA63-00444A	GASKET-WINDOW	NBR			●
27	DA63-01750A	GASKET-BUTTON,PCB	SILICONE			●
28	DA64-00959A	BUTTON-PCB	ABS,WHITE,SEMI			●
29	DA63-00235A	COVER-LAMP REF	PP(BJ-730T4),NTR	●	●	●
	DA63-00235B		PP(BJ-730T4),LIGHT BLUE	●	●	●
	DA63-00235C		PP(RJ-700)	●	●	●
30	DA32-10105B	SENSOR ASSY	502AT,-10~35,5V	●	●	●
31	4713-001140	LAMP-INCANDESCENT	240V,25W,BLU,25x	●	●	●
	4713-001141		130V,25W,BLU,25x	●	●	●
32	DA63-00234A	COVER-SUCTION REF	PP,WHITE	●	●	●
33	DA63-10467A	COVER-SENSOR	HIPS	●	●	●

2-3. Door

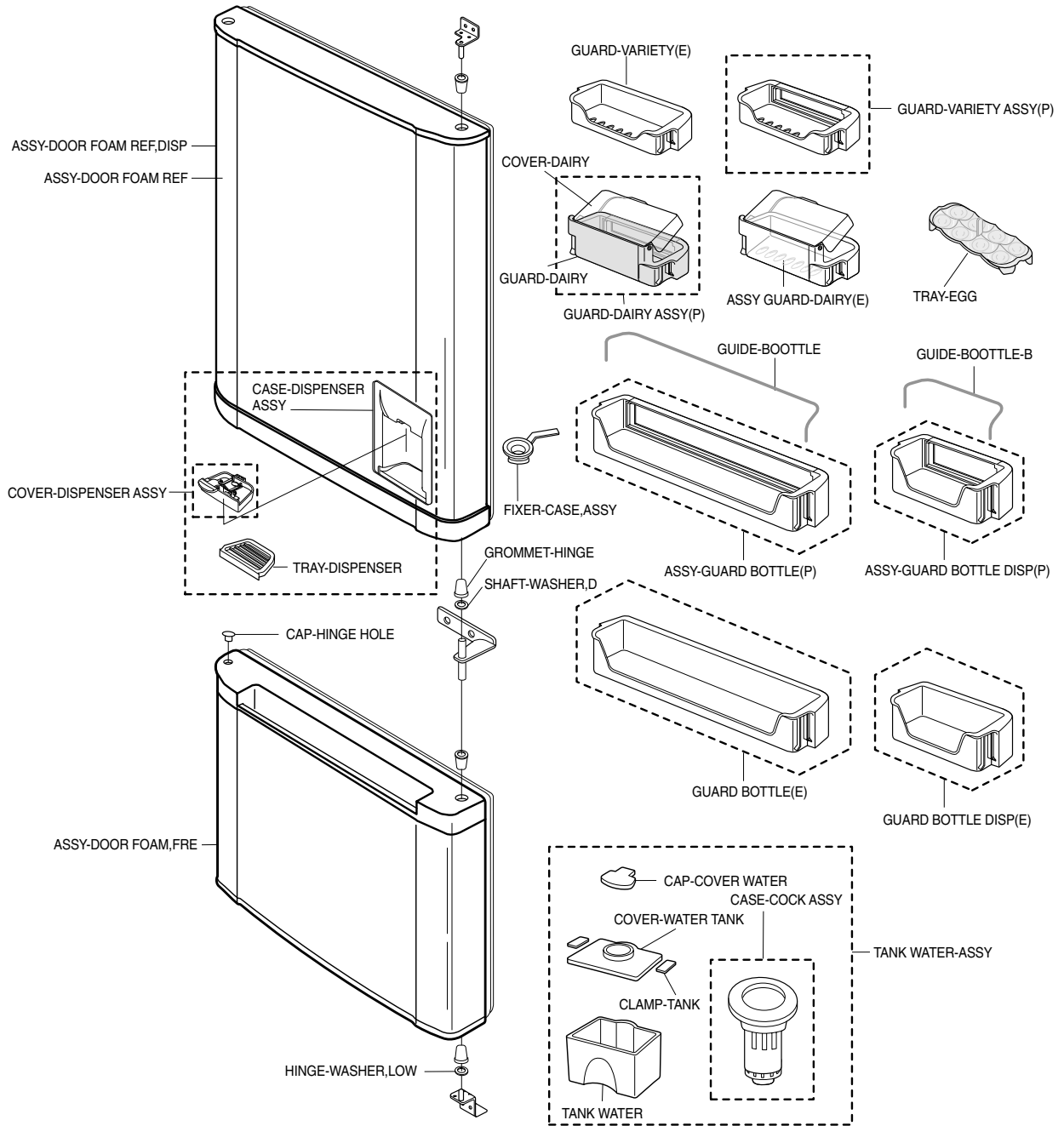

■ Door List

NO	CODE-NO	ITEM	SPECIFICATION	OPTION		
				RL36/39E	RL39W	RL36/39S
1	DA97-01397A	ASSY GUARD VARITY	PREMIUM	●	●	
2	DA63-01724A	GUARD-VARITY	GPPS(HF-2660)			●
3	DA66-00058A	TRAY-EGG	PP	●	●	●
4	DA97-01398A	ASSY GUARD-DAIRY	PREMIUM	●	●	
5	DA97-01408A	ASSY GUARD-DAIRY	GPPS(HF-2660)			●
6	DA97-01400A	ASSY GUARD BOTTLE-DISPENSER	PREMIUM		●	
7	DA97-01399A	ASSY GUARD-BOTTLE	PREMIUM	●		
8	DA63-01728A	GUARD-BOTTLE	GPPS(HF-2660)			●
9	DA71-00119A	GUIDE BOTTLE-B	RL39(D),MSWR10,SNC2		●	
10	DA71-00118A	GUIDE BOTTLE	RL36/39,MSWR10,SNC2	●		●
11	DA91-01722A	ASSY-DOOR FOAM FRE	RL39,SNOW WHITE	●		●
	DA91-01722B		RL39(DIS),SNOW WHITE		●	
	DA91-01722C		RL36,SNOW WHITE	●		●
	DA91-01722D		RL39,MIST SILVER	●		●
	DA91-01722E		RL39(DIS),MIST SILVER		●	
	DA91-01722F		RL36,MIST SILVER	●		●
12	DA91-01724A	ASSY-DOOR FOAM REF(DIS)	RL39DISP,SNOW WHITE		●	
	DA91-01724B		RL39DISP,MIST SILVER		●	
	DA91-01723A		RL39,SNOW WHITE	●		●
13	DA91-01723B	ASSY DOOR FOAM REF	RL36,SNOW WHITE	●		●
	DA91-01723C		RL39,MIST SILVER	●		●
	DA91-01723D		RL36,MIST SILVER	●		●
14	DA97-01402A	ASSY COVER-DISPENSER	RL39(DIS),SNOW WHITE		●	
	DA97-01402B		RL39(DIS),MIST SILVER		●	
15	DA61-20146A	SPRING-ETC LEVER	STS304		●	
16	DA63-01735A	COVER-DISPENSER	ABS,SNOW WHITE		●	
	DA63-01735B		ABS,MIST SILVER		●	
17	DA64-00121A	KEY-LEVER	POM		●	
18	DA64-00965A	KNOB-LEVER DISPENSER	ABS(MP-0160),SILVER		●	
19	DA66-00062A	LEVER-DISPENSER	POM,NTR		●	
20	DA97-01433A	ASSY CASE-DISPENSER	RL39(DIS),SNOW WHITE		●	
	DA97-01433B		RL39(DIS),MIST SILVER		●	
21	DA63-01715A	TRAY DISPENSER	ABS(HG-0760H),SNOW WHITE		●	
	DA63-01715B		ABS(HG-0760H),MIST SILVER		●	
22	DA71-20155B	ASSY FIXER-CASE	RL39,DISPENSER		●	
23	DA74-00054A	ASSY TANK-WATER	RL39,DISPENSER		●	
24	DA61-00139A	ASSY CASE-COCK	RL39,DISPENSER		●	
25	DA63-00240A	COVER-WATER TANK	PP		●	
26	DA65-20004A	CLAMP-TANK	PC-ABS		●	
27	DA67-30216B	CAP-COVER TANK	PP		●	
28	DA74-00051A	TANK-WATER	PP		●	
29	DA67-00194A	CAP-HINGE HOLE	PP,SNOW WHITE	●	●	●
	DA67-00194F		PP,MIST SILVER	●	●	●

2-4. Cabinet Parts & Unit

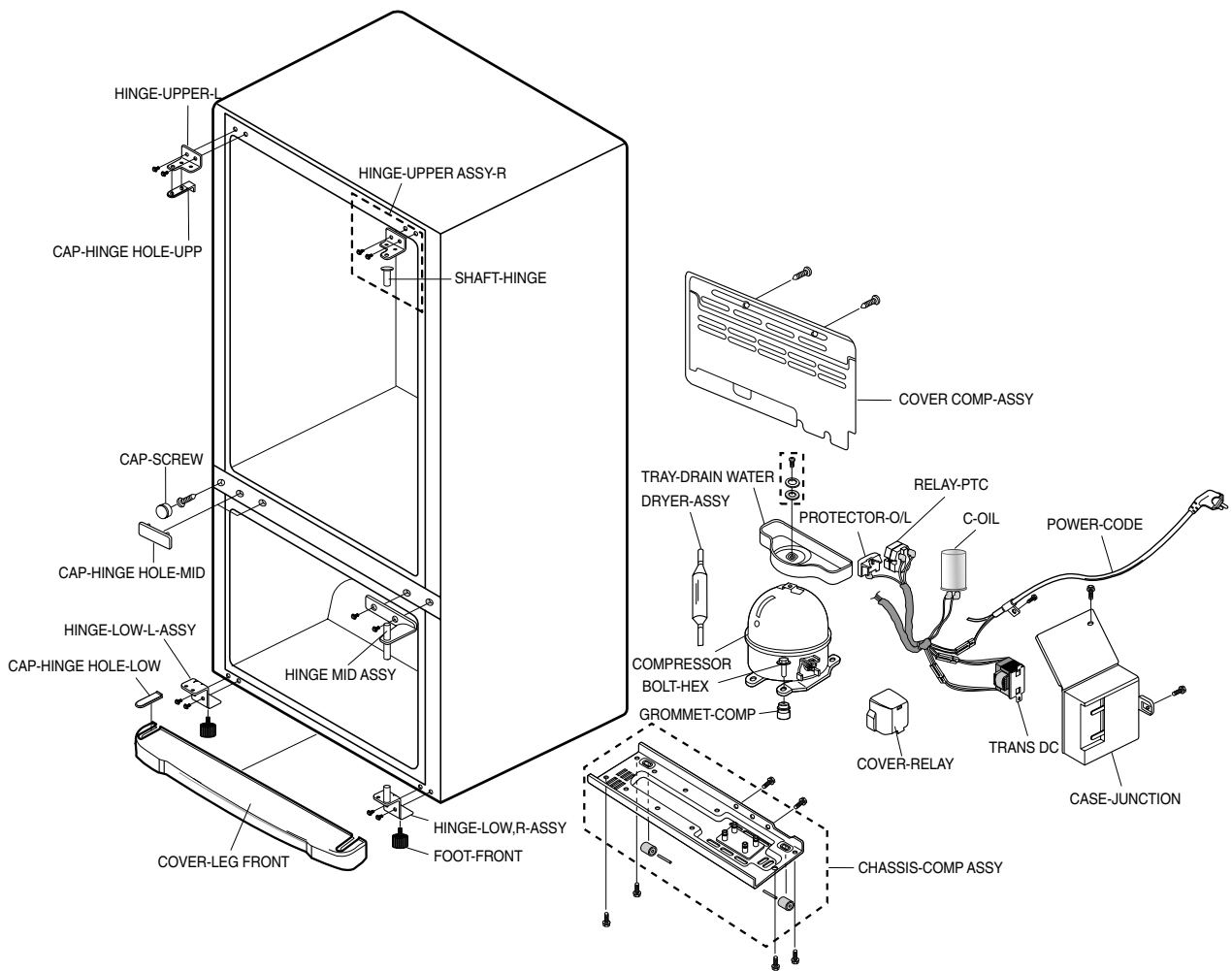

■ Cabinet Parts & Unit Lists

NO	CODE-NO	ITEM	SPECIFICATION	OPTION		
				RL36/39E	RL39W	RL36/39S
1	DA61-00073A	HINGE-UPPER ASSY-R	SHP1,T2.7	●	●	●
2	DA61-00075A	HINGE-UPPER-L	SHP1,T2.7	●	●	●
3	DA61-00146A	HINGE-MID ASSY	SHP1,T4.0	●	●	●
4	DA61-00119A	HINGE-MID	SHP1,T4.0	●	●	●
5	DA63-00443A	SHIM HINGE-MID	RD-PVC	●	●	●
6	DA67-00195A	CAP-HINGE HOLE-MID	PP,SNOW WHITE	●	●	●
7	DA67-00196A	CAP-HINGE HOLE-UPP	PP,SNOW WHITE	●	●	●
	DA67-00196F		PP,MIST SILVER	●	●	●
8	DA97-00919A	ASSY HINGE LOW-R	ZPC2,T4.0	●	●	●
9	DA61-00072A	HINGE-LOWER	SHP1,T4.0	●	●	●
10	DA97-00920A	ASSY HINGE LOW-L	ZPC2,T4.0	●	●	●
11	DA61-00805A	FOOT FRONT	PP,PI44,NTR	●	●	●
12	DA97-01431A	ASSY COVER-LEG FRONT	PP(BJ-730T4),SMOW WHITE	●	●	●
	DA97-01431B		PP(BJ-730T4),MIST SILVER	●	●	●
13	DA63-01733A	COVER LEG-FRONT	PP(BJ-730T4),SNOW WHITE	●	●	●
	DA63-01733B		PP(BJ-730T4),MIST SILVER	●	●	●
14	DA67-00197A	CAP-HINGE HOLE-LOW	PP,SNOW WHITE	●	●	●
	DA67-00197F		PP,MIST SILVER	●	●	●
15	DA63-00398A	COVER COMP-ASSY	SBHG1,T0.4	●	●	●
16	DA67-00026F	TRAY-DRAIN WATER ASSY	SCP2	●	●	●
17	DA73-30102B	DRYER-ASSY	CU,OD18.85,ID2,L102	●	●	●
18	DA97-00726A	ASSY-CHASSIS COMP	T1.2	●	●	●
19	DA63-40234C	GROMMET-COMP	ID10 H9.7,NBR	●	●	●
20	DA60-20008A	BOLT-HEX	SM30C,L42.6	●	●	●
21	DA63-10352A	COVER-RELAY	PP	●	●	●
22	DK4A1QL1U/E0	COMPRESSOR	230~240V/50Hz	●	●	●
	SK170H-L1U		220V/50Hz	●	●	●
	DK172P-L2U		127V/60Hz	●	●	●
23	2501-001185	C-OIL	350VAC/3.5uF	●	●	●
	2501-001186		350VAC/5uF	●	●	●
	2501-001045		250VAC/12uF	●	●	●
24	DA34-10003H	PROTECTOR-P/L	4TM213PHBYY-53	●	●	●
	DA34-10003K		4TM232SHBYY-53	●	●	●
	DA34-10003T		4TM435PHBYY-53	●	●	●
25	DA35-10013B	RELAY-PTC	J531Q35E330M385-2	●	●	●
	DA35-10013N		J531Q33E100M200-2	●	●	●
26	DA26-00003A	TRANS-DC	240V,17V,0.2A	●	●	●
	DA26-00003B		115~127V,17V,0.2A	●	●	●
27	DA61-00089B	CASE-JUNCTION	PP,NTR	●	●	●
28	DA39-10115D	POWER-CODE	UCP-2,250V,10/16A,L2100	●	●	●
29	DA66-00060A	SHAFT-HINGE	SWCH10A,ZPC2	●	●	●