



# MICROWAVE OVEN

CE2914 / CE2914T (WHITE)

# ***SERVICE*** Manual

## MICROWAVE OVEN

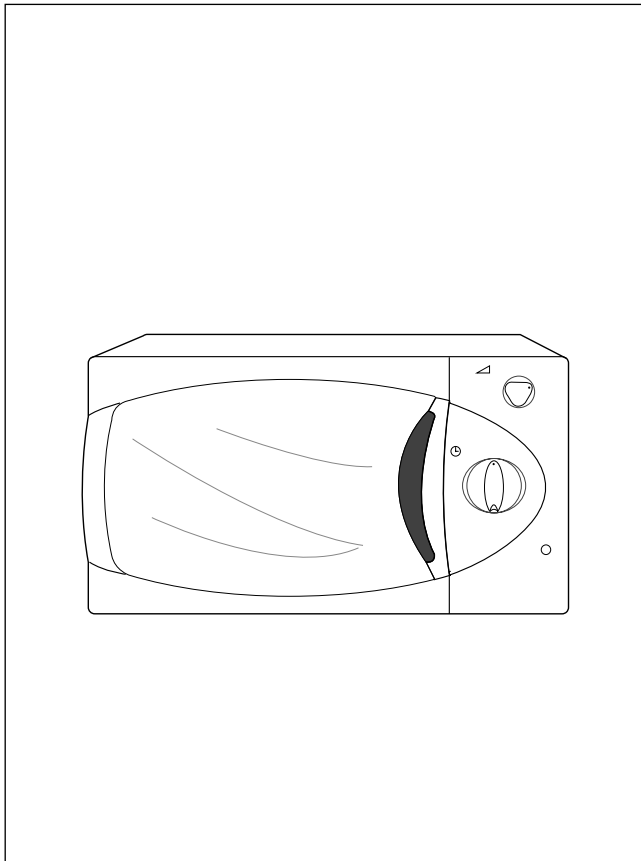

## CONTENTS

1. Precaution
2. Specifications
3. Operating Instructions
4. Disassembly and Reassembly
5. Alignment and Adjustments
6. Troubleshooting
7. Exploded Views and Parts List
8. Schematic Diagrams

## **PRECAUTIONS TO BE OBSERVED BEFORE AND DURING SERVICING TO AVOID POSSIBLE EXPOSURE TO EXCESSIVE MICROWAVE ENERGY**

- (a) Do not operate or allow the oven to be operated with the door open.
- (b) Make the following safety checks on all ovens to be serviced before activating the magnetron or other microwave source, and make repairs as necessary:
  - (1) Interlock operation,
  - (2) proper door closing,
  - (3) seal and sealing surfaces (arcing, wear, and other damage),
  - (4) damage to or loosening of hinges and latches,
  - (5) evidence of dropping or abuse.
- (c) Before turning on microwave power for any service test or inspection within the microwave generating compartments, check the magnetron, wave guide or transmission line, and cavity for proper alignment, integrity, and connections.
- (d) Any defective or misadjusted components in the interlock, monitor, door seal, and microwave generation and transmission systems shall be repaired, replaced, or adjusted by procedures described in this manual before the oven is released to the owner.
- (e) A Microwave leakage check to verify compliance with the Federal performance standard should be performed on each oven prior to release to the owner.

---

# 1. Precaution

---

Follow these special safety precautions. Although the microwave oven is completely safe during ordinary use, repair work can be extremely hazardous due to possible exposure to microwave radiation, as well as potentially lethal high voltages and currents.

## 1-1 Safety precautions ( ⚠ )

---

1. All repairs should be done in accordance with the procedures described in this manual. This product complies with Federal Performance Standard 21 CFR Subchapter J (DHHS).
2. Microwave emission check should be performed to prior to servicing if the oven is operative.
3. If the oven operates with the door open : Instruct the user not to operate the oven and contact the manufacturer and the center for devices and radiological health immediatly.
4. Notify the Central Service Center if the microwave leakage exceeds 5 mW/cm<sup>2</sup>
5. Check all grounds.
6. Do not power the MWO from a "2-prong" AC cord. Be sure that all of the built-in protective devices are replaced. Restore any missing protective shields.
7. When reinstalling the chassis and its assemblies, be sure to restore all protective devices, including: nonmetallic control knobs and compartment covers.
8. Make sure that there are no cabinet openings through which people--particularly children--might insert objects and contact dangerous voltages. Examples: Lamp hole, ventilation slots.
9. Inform the manufacturer of any oven found to have emission in excess of 5 mW/cm<sup>2</sup>, Make repairs to bring the unit into compliance at no cost to owner and try to determine cause. Instruct owner not to use oven until it has been brought into compliance.
10. Service technicians should remove their watches while repairing an MWO.
11. To avoid any possible radiation hazard, replace parts in accordance with the wiring diagram. Also, use only the exact replacements for the following parts: Primary and secondary interlock switches, interlock monitor switch.
12. If the fuse is blown by the Interlock Monitor Switch: Replace all of the following at the same time: Primary, door sensing switch and power relay, as well as the Interlock Monitor Switch. The correct adjustment of these switches is described elsewhere in this manual. Make sure that the fuse has the correct rating for the particular model being repaired.
13. Design Alteration Warning: Use exact replacement parts only, i.e., only those that are specified in the drawings and parts lists of this manual. This is especially important for the Interlock switches, described above. Never alter or add to the mechanical or electrical design of the MWO. Any design changes or additions will void the manufacturer's warranty.10.Always unplug the unit's AC power cord from the AC power source before attempting to remove or reinstall any component or assembly.
14. Never defeat any of the B+ voltage interlocks. Do not apply AC power to the unit (or any of its assemblies) unless all solid-state heat sinks are correctly installed.
15. Some semiconductor ("solid state") devices are easily damaged by static electricity. Such components are called Electrostatically Sensitive Devices (ESDs). Examples include integrated circuits and field-effect transistors.  
  
Immediately before handling any semiconductor components or assemblies, drain the electrostatic charge from your body by touching a known earth ground.
16. Always connect a test instrument's ground lead to the instrument chassis ground *before* connecting the positive lead; always remove the instrument's ground lead last.

CENTRAL SERVICE CENTER

---

## 1-2 Special Servicing Precautions (Continued)

---

17. When checking the continuity of the witches or transformer, always make sure that the power is OFF, and one of the lead wires is disconnected.
18. Components that are critical for safety are indicated in the circuit diagram by shading,  $\triangle$  or  $\triangleleft$  .
19. Use replacement components that have the same ratings, especially for flame resistance and dielectric strength specifications. A replacement part that does not have the same safety characteristics as the original might create shock, fire or other hazards.

---

## 1-3 Special High Voltage Precautions

---

1. High Voltage Warning  
Do not attempt to measure any of the high voltages--this includes the filament voltage of the magnetron. High voltage is present during any cook cycle.  
  
Before touching any components or wiring, always unplug the oven and discharge the high voltage capacitor (See Figure 1-1)
2. The high-voltage capacitor remains charged about 30 seconds after disconnection. Short the negative terminal of the high-voltage capacitor to the oven chassis. (Use a screwdriver.)
3. High voltage is maintained within specified limits by close-tolerance, safety-related components and adjustments. If the high voltage exceeds the specified limits, check each of the special components.



Fig. 1-1. Discharging the High Voltage Capacitor

---

## 2. Specifications

---

### 2-1 Table of Specifications

---

TIMER	60 MINUTES
POWER SOURCE	230V 50Hz, AC
POWER CONSUMPTION	MICROWAVE : 1,500W GRILL : 1300W
OUTPUT POWER	FROM 100 TO 900W (IEC-705 TEST PROCEDURE)
OPERATING FREQUENCY	2,450MHz
MAGNETRON	OM75PN(31)ESS
COOLING METHOD	COOLING FAN MOTOR
OUTSIDE DIMENSIONS	517(W) x 297(H) x 379(D)

---

## 3. Operating Instructions

---

### 3-1 Control Panel

---

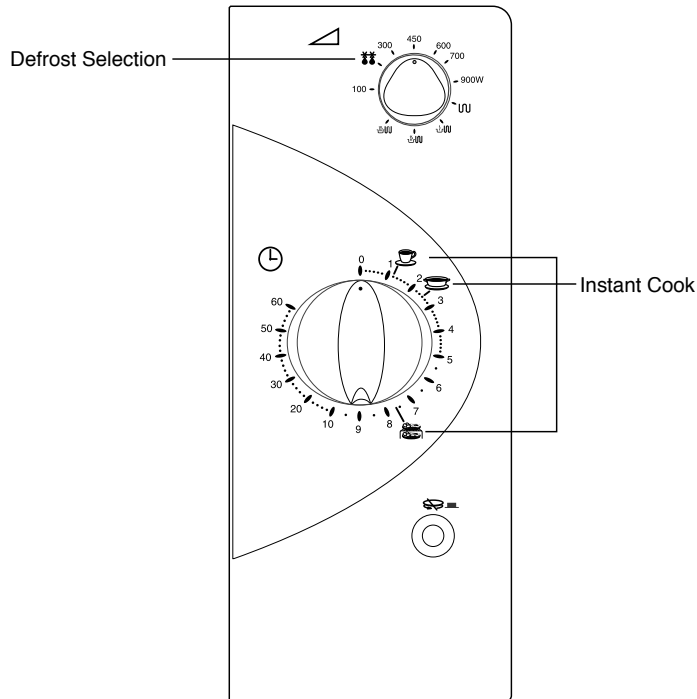

### 3-2 Features & External Views

---

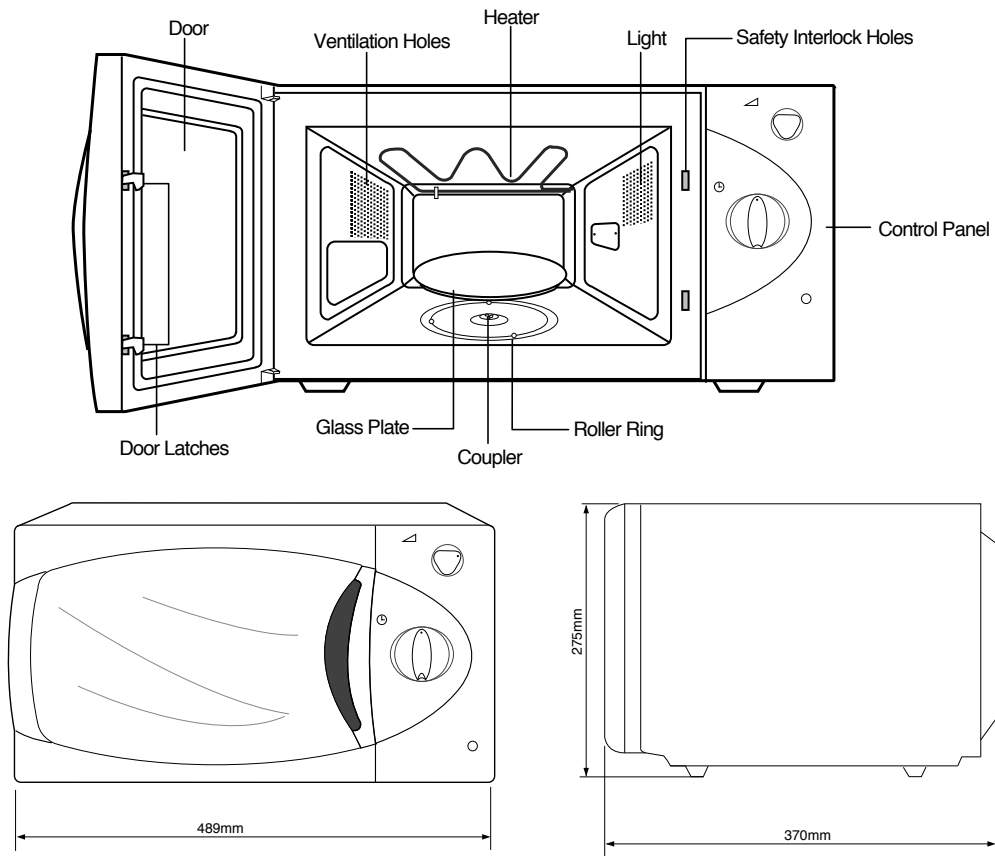

---

## 4. Disassembly and Reassembly

---

### 4-1 Replacement of Magnetron, Motor Assembly and Lamp

---

Remove the magnetron including the shield case, permanent magnet, choke coils and capacitors (all of which are contained in one assembly).

1. Disconnect all lead wires from the magnetron and lamp.
2. Remove a screw securing the magnetron supporter.
3. Remove the magnetron supporter.
4. Remove the air cover.
5. Remove screws securing the magnetron to the wave guide.
6. Take out the magnetron very carefully.
7. Remove screws from the back panel.
8. Take out the fan motor.
9. Remove the oven lamp by rotating to pull out from hole of air cover.

NOTE1: When removing the magnetron, make sure that its antenna does not hit any adjacent parts, or it may be damaged.

NOTE2: When replacing the magnetron, be sure to remount the magnetron gasket in the correct position and make sure the gasket is in good condition.

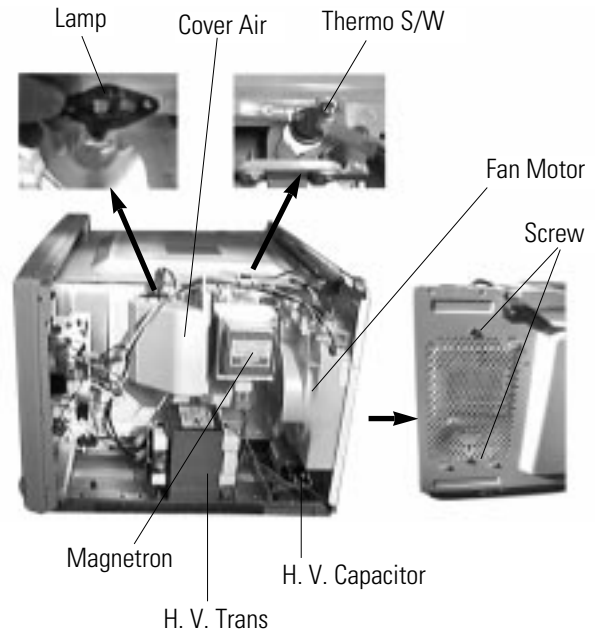

### 4-1 Replacement of High Voltage Transformer

---

1. Discharge the high voltage capacitor.
2. Disconnect all the leads.
3. Remove the mounting bolts.
4. Reconnect the leads correctly and firmly.

#### PRECAUTION

Servicemen should remove their watches whenever working close to or replacing the magnetron.

#### PRECAUTION

There exists HIGH VOLTAGE ELECTRICITY with high current capabilities in the circuits of the HIGH VOLTAGE TRANSFORMER secondary and filament terminals. It is extremely dangerous to work on or near these circuits with the oven energized. DO NOT measure the voltage in the high voltage circuit including filament voltage of magnetron.

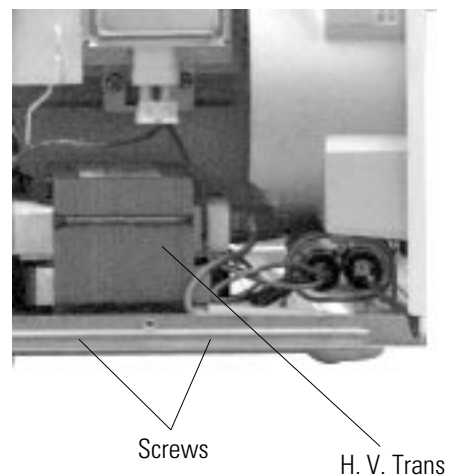

## 4-3 Replacement of Door Assembly

### 4-3-1 Removal of Door Assembly

Remove hex bolts securing the upper hinge and lower hinge. Then remove the door assembly.

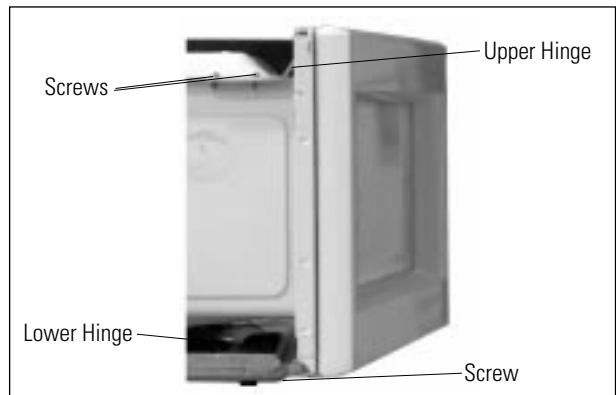

### 4-3-2 Removal of Door "C"

Insert flat screwdriver into the gap between Door "E" and Door "C" to remove Door "C". Be careful when handling Door "C" because it is fragile.

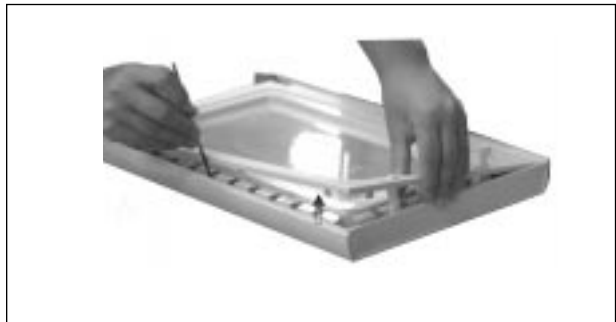

### 4-3-3 Removal of Door "E"

Following the procedure as shown in the figure, insert and bend a thin metal plate between Door "E" and Door "A" until you hear the 'tick' sound.

1. Insertion depth of the thin metal plate should be 0.5mm or less.

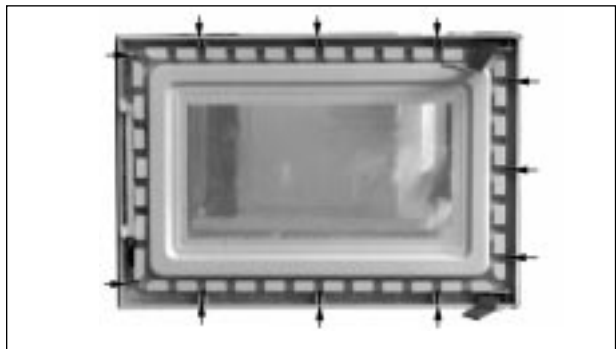

### 4-3-4 Removal of Key Door & Spring

Remove pin hinge from Door "E"  
Detach spring from Door "E" and key door.

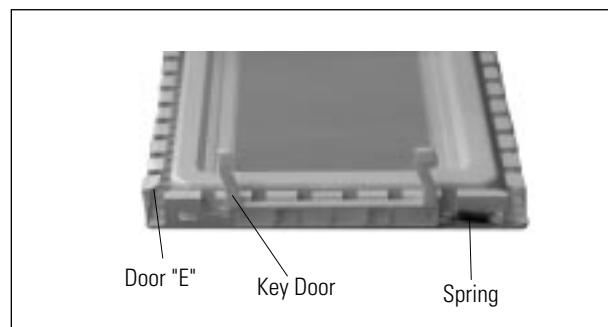



### 4-3-5 Reassembly Test

After replacement of the defective component parts of the door, reassemble it and follow the instructions below for proper installation and adjustment so as to prevent an excessive microwave leakage.

1. When mounting the door to the oven, be sure to adjust the door parallel to the bottom line of the oven face plate by moving the upper hinge and lower hinge in the direction necessary for proper alignment.
2. Adjust so that the door has no play between the inner door surface and oven front surface. If the door assembly is not mounted properly, microwave energy may leak from the space between the door and oven.
3. Do the microwave leakage test.

### 4-4 Replacement of Fuse

1. Disconnect the oven from the power source.
2. When 15A fuse blows out by the operation of interlock monitor switch failure, replace the primary interlock switch, door sensing switch, monitor switch and power relay.
3. When the above three switches operate properly, check if any other part such as the control circuit board, blower motor or high voltage transformer is defective.

### 4-5 Replacement of Drive Motor

1. Take out the glass tray, guide roller and coupler from cavity.
2. Turn the oven upside down to replace the drive motor.
3. Remove a screw securing the drive motor cover.
4. Disconnect all the lead wires from the drive motor.
5. Remove screws securing the drive motor to the cavity.
6. Remove the drive motor.
7. When replacing the drive motor, be sure to remount it in the correct position.
8. Connect all the leads to the drive motor.
9. Screw the drive motor cover to the base plate with a screw driver.
10. Remount the coupler in the correct position.

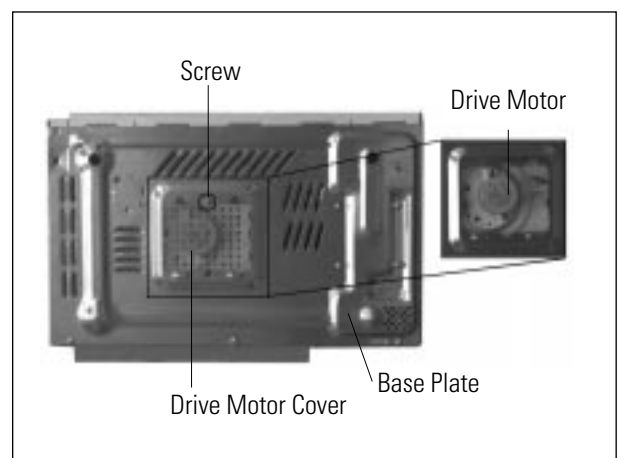

## 4-6 Replacement of Control Circuit Board

---

### 4-6-1 Removal of Ass'y Control Box

1. Disconnect the connectors from the control box assembly.
2. Remove screws securing the control box assembly.
3. Remove the knobs of the control box Ass'y.
4. Remove the screw securing the timer.

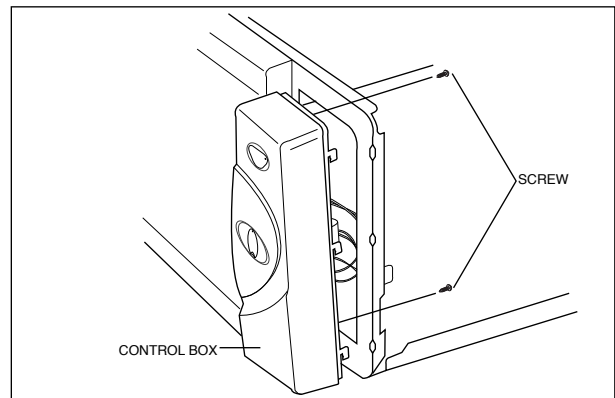

---

## 5. Alignment and Adjustments

---

### PRECAUTION

1. High voltage is present at the high voltage terminals during any cook cycle.
2. It is neither necessary nor advisable to attempt measurement of the high voltage.
3. Before touching any oven components or wiring, always unplug the oven from its power source and discharge the high voltage capacitor.

---

### 5-1 High Voltage Transformer

---

1. Remove connectors from the transformer terminals and check continuity.
2. Normal resistance readings are as follows:

Secondary	Approx. 100 $\Omega$
Filament	Approx. 0 $\Omega$
Primary	Approx. 1.456 $\Omega$

(Room temperature = 20°C)

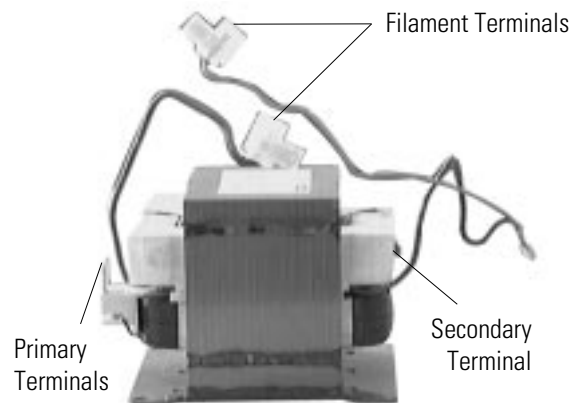

---

### 5-2 Magnetron

---

1. Continuity checks can indicate only an open filament or a shorted magnetron. To diagnose an open filament or shorted magnetron :
2. Isolate the magnetron from the circuit by disconnecting its leads.
3. A continuity check across the magnetron filament terminals should indicate one ohm or less.
4. A continuity check between each filament terminal and magnetron case should read open.

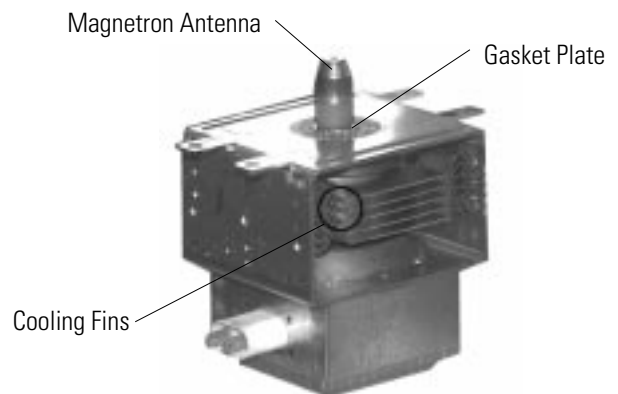

---

### 5-3 High Voltage Capacitor

---

1. Check continuity of the capacitor with the meter set at the highest resistance scale.
2. Once the capacitor is charged, a normal capacitor shows continuity for a short time, and then indicates 9M $\Omega$ .
3. A shorted capacitor will show continuous continuity.
4. An open capacitor will show constant 9M $\Omega$ .
5. Resistance between each terminal and chassis should read infinite.

## 5-4 High Voltage Diode

1. Isolate the diode from the circuit by disconnecting its leads.
2. With the ohm-meter set at the highest resistance scale, measure across the diode terminals. Reverse the meter leads and read the resistance. A meter with 6V, 9V or higher voltage batteries should be used to check the front-to back resistance of the diode (otherwise an infinite resistance may be read in both directions). The resistance of a normal diode will be infinite in one direction and several hundred KΩ in the other direction.

## 5-5 Adjustment of Primary Switch, Door Sensing Switch and Monitor Switch

### Precaution

For continued protection against radiation hazard, replace parts in accordance with the wiring diagram and be sure to use the correct part number for the following switches: Primary and secondary interlock switches, and the interlock monitor switch (replace all together). Then follow the adjustment procedures below. After repair and adjustment, be sure to check the continuity of all interlock switches and the interlock monitor switch.

1. When mounting Primary switch and Interlock Monitor switch to Latch Body, consult the figure.
2. No specific adjustment during installation of Primary switch and Monitor switch to the latch body is necessary.
3. When mounting the Latch Body to the oven assembly, adjust the Latch Body by moving it so that the oven door will not have any play in it. Check for play in the door by pulling the door assembly. Make sure that the latch keys move smoothly after adjustment is completed. Completely tighten the screws holding the Latch Body to the oven assembly.
4. Reconnect to Monitor switch and check the continuity of the monitor circuit and all latch switches again by following the components test procedures.
5. Confirm that the gap between the switch housing and the switch actuator is no more than 0.5mm when door is closed.

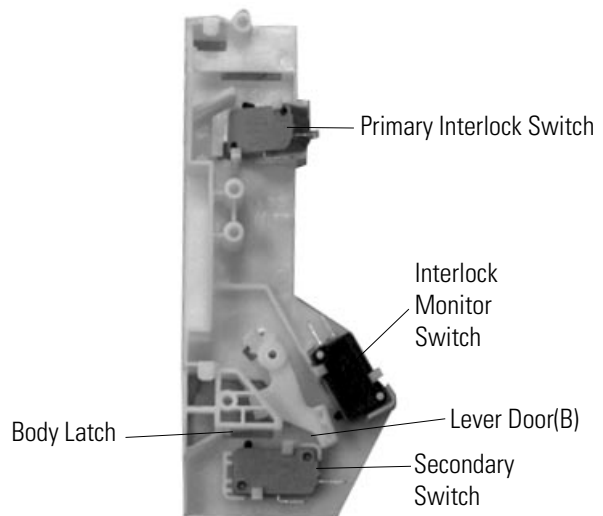

	Door Open	Door Closed
Primary switch	∞	0
Monitor switch (COM-NC)	0	∞
Monitor switch (COM-NO)	∞	0
Secondary S/W	∞	0

## 5-6 Output Power of Magnetron

### CAUTION MICROWAVE RADIATION

PERSONNEL SHOULD NOT ALLOW EXPOSURE TO MICROWAVE RADIATION FROM MICROWAVE GENERATOR OR OTHER PARTS CONDUCTING MICROWAVE ENERGY.

The output power of the magnetron can be measured by performing a water temperature rise test.

Equipment needed :

\* Two 1-liter cylindrical borosilicate glass vessel (Outside diameter 190 mm)

\* One glass thermometer with mercury column

NOTE: Check line voltage under load. Low voltage will lower the magnetron output. Make all temperature and time tests with accurate equipment.

1. Fill the one liter glass vessel with water.
2. Stir water in glass vessel with thermometer, and record glass vessel's temperature ("T1", 10±1°C).
3. After moving the water into another glass vessel, place it in the center of the cooking tray. Set the oven to high power and operate for 52 seconds exactly. (2 seconds included as a holding time of magnetron oscillation:)
4. When heating is finished, stir the water again with the thermometer and measure the temperature ("T2").
5. Subtract T1 from T2. This will give you the water temperature rise. ( $\Delta T$ )
6. The output power is obtained by the following formula;

$$\text{Output Power} = \frac{4.187 \times 1000 \times \Delta T}{49}$$

42 : Heating Time (sec)  
4.187 : Coefficient for Water  
1000 : Water (cc)  
 $\Delta T$  : Temperature Rise (T2-T1)

$$* \text{Output (W)} = 100 \times \Delta T$$

7. Normal temperature rise for this model is 9°C to 11°C at 'HIGH'.

NOTE 1 : Variations or errors in the test procedure will cause a variance in the temperature rise. Additional power test should be made if temperature rise is marginal.

NOTE 2 : Output power in watts is computed by multiplying the temperature rise (step E) by a factor of 91 times the of centigrade temperature.

## 5-7 Procedure for Measurement of Microwave Energy Leakage

- 1) Pour  $275 \pm 15$ cc of  $20 \pm 5^\circ\text{C}$  ( $68 \pm 9^\circ\text{F}$ ) water in a beaker which is graduated to 600cc, and place the beaker in the center of the oven.
- 2) Start to operate the oven and measure the leakage by using a microwave energy survey meter.
- 3) Set survey meter with dual ranges to 2,450MHz.
- 4) When measuring the leakage, always use the 2 inch spacer cone with the probe. Hold the probe perpendicular to the cabinet door. Place the spacer cone of the probe on the door and/or cabinet door seam and move along the seam, the door viewing window and the exhaust openings moving the probe in a clockwise direction at a rate of 1 inch/sec. If the leakage testing of the cabinet door seam is taken near a corner of the door, keep the probe perpendicular to the areas making sure that the probe end at the base of the cone does not get closer than 5cm to any metal. If it gets closer than 5cm, erroneous readings may result.
- 5) Measured leakage must be less than  $4\text{mW}/\text{cm}^2$ , after repair or adjustment.

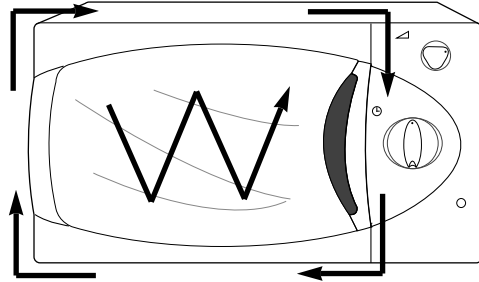

Maximum allowable leakage is  $5\text{mW}/\text{cm}^2$ .  
 $4\text{mW}/\text{cm}^2$  is used to allow for measurement and meter accuracy

## 5-8 Check for Microwave Leakage

1. Remove the outer panel.
2. Pour  $275 \pm 15$ cc of  $20 \pm 5^\circ\text{C}$  ( $68 \pm 9^\circ\text{F}$ ) water in a beaker which is graduated to 600cc, and place the beaker in the center of the oven.
3. Start the oven at the highest power level.
4. Set survey meter dual ranges to 2,450MHz.
5. Using the survey meter and spacer cone as described above, measure around the opening of magnetron, the surface of the air guide and the surface of the wave guide as shown in the following photo. (but avoid the high voltage components.) The reading should be less than  $4\text{mW}/\text{cm}^2$ .

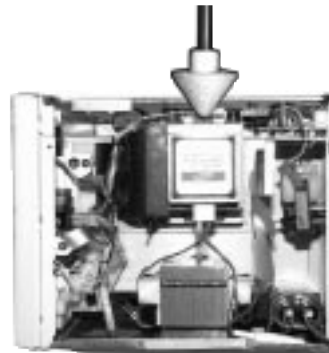

## 5-9 Note on Measurement

- 1) Do not exceed the limited scale.
- 2) The test probe must be held on the grip of the handle, otherwise a false reading may result when the operator's hand is between the handle and the probe.
- 3) When high leakage is suspected, do not move the probe horizontally along the oven surface; this may cause damage to the probe.
- 4) Follow the recommendation of the manufacturer of the microwave energy survey meter.

## 5-10 Leakage Measuring Procedure

- 5-10-1 Record keeping and notification after measurement
- 1) After adjustment and repair of a radiation preventing device, make a repair record for the measured values, and keep the data.
  - 2) If the radiation leakage is more than  $4\text{mW}/\text{cm}^2$  after determining that all parts are in good condition, functioning properly and the identical parts are replaced as listed in this manual notify that fact to ;

### CENTRAL SERVICE CENTER

- 5-10-2 At least once a year have the microwave energy survey meter checked for accuracy by its manufacturer.

## 6. Troubleshooting

### WARNING FOR HIGH VOLTAGE

4000 VOLTS EXIST AT THE HIGH VOLTAGE AREA. DO NOT OPERATE THE OVEN WITH CABINET PARTS REMOVED. DO NOT REMOVE THE CABINET PARTS IF THE POWER SUPPLY CORD IS PLUGGED IN THE WALL OUTLET. UNPLUG THE POWER CORD BEFORE SERVICING.

### 6-1 Electrical Malfunction

Parts	Cause	Diagnosis	Remedy
Fuse blows out when door is opened.	Defective primary interlock switch ary winding.	Check continuity of the primary switch terminals with wire removed using a multimeter. If there is continuity between switch terminals when door is opened, the switch is defective.	Replace the primary interlock switch
	Defective interlock monitor switch	Check continuity of the monitor switch terminals with wire removed by using a multimeter. If there is continuity between switch terminals when the door is closed, the switch is defective.	Replace the interlock monitor switch
Fuse is open.	Layer short of the secondary coil of H. V. Transformer	The fuse will not blow right away, but if it blows in a few seconds, then there is a layer short. If the fuse blows with H. V. Trans secondary open, the transformer may be faulty.	Replace H. V. Transformer
Oven lamp does not light.	1) Fuse blown out	Check fuse.	Replace the fuse.
	2) Poor contact of power cord	Check continuity of power supply cord. Also check whether the power cord is securely wired.	Adjust or replace the power supply cord.
	3) Defective lamp	The fan motor rotates, but lamp does not light.	Replace the lamp.
	4) Defective timer contacts	Check the terminals of timer for continuity, turning the timer knob ON and OFF repeatedly.	Replace the timer.
	5) Thermal cutout S/W open	In this case the oven lamp and fan do not turn on	Replace the thermal cutout S/W
Fan does not operate.	1) Defective fan motor.	If 220~230V is found at motor terminals, the motor should be replaced.	Replace the motor.
	2) Defective contacts of timer	The oven lamp does not light and fan motor does not operate.	Replace the timer.

NOTE: Interlock monitor switch must be replaced when the fuse is blown out.

## 6-1 Electrical Malfunction (Continued)

Parts	Cause	Diagnosis	Remedy
Microwave turns off during cooking cycle.	1) Too small a load	If a small amount of food is heated for a long time, period of microwave may turn off during operation.	To increase the oven load, add a glass of water into the oven.
	2) Defective magnetron thermal cutout S/W	Check to see if the magnetron thermal cutout switch is activated at a temperature higher than 150°C.	Replace thermal cutout switch.
Electric shock is felt.	Incomplete grounding	Make sure that grounding of the power supply cord has been done properly.	Rewire.
Door does not operate properly	1) Broken door hinges	Remove the cabinet for inspection. Check the door hinge.	Replace door hinges.
	2) Missing or loose screw	Check if the screws are secured well to the door hinge.	Fasten or tighten.
Timer does not operate.	1) Defective timer motor	If the timer does not operate with 220~230V applied to the terminals, the timer motor may be faulty.	Replace timer.
	2) Defective contacts of timer S/W	The lamp does not light.	Replace timer
Cooking tray does not rotate.	1) Defective drive motor	Check to see if 220~230V exists at the motor terminals. If so, motor will be defective.	Replace drive motor.
	1) Blocking of the ventilator	Check if the air inlet or outlet ventilation is blocked by the wall or other objects.	Keep a distance of 100mm from the wall or the objects.
Magnetron thermal cutout switch OFF	2) Defective fan motor	If the fan motor does not operate with 220~230V applied to the terminal, the motor may be faulty.	Replace fan motor.
	3) Too small a load or no load	If a small amount of food is heated repeatedly over a long period of time, microwave turns off during operation.	To increase the oven load, place a glass of water into the oven.



## 6-2 Unsatisfactory Cooking

Parts	Cause	Diagnosis	Remedy
Food is not heated.	1) Open cathode of magnetron	Check the terminals with a multimeter to see if the heater circuit is open.	Replace magnetron.
	2) Defective H. V. Diode	Check the H. V. Diode for continuity in the reverse and normal directions using megger. If there is continuity in the reverse direction, the H. V. Diode may be faulty. (In this event H. V. Capacitor will be hot)	Replace H. V. Diode.
	3) Shorted magnetron	Connect megger leads to quick-connect terminal & body of the magnetron if there is continuity, the magnetron may be faulty. (In this case the main fuse will be blown)	Replace magnetron.
	4) Defective magnetron	If there is a crack in the magnetron antenna (dome), the magnetron is defective.	Replace magnetron.
	5) Poor contact of primay interlock switch	Check if the screws are secured well to the door hinge. and pressing it ON and OFF repeatedly.	Replace or adjust.
	6) Open coil of H. V. Transformer	Check the continuity of primary coil and secondary coil. If there is no continuity, H. V. Transformer is defective.	Replace the H. V. Transformer.
	7) Shorted H. V. capacitor	Check the continuity of capacitor. If the capacitor shorts, the fuse blows	Replace the H. V. Capacitor.
	8) Monitor fuse blown out	Check the monitor fuse (on the noise filter)	Replace the Monitor fuse

## 6-3 Part Check List

Symptom	Related Parts	Check Points	Remedy
Microwave cooking does not work.	H.V.Transformer	1) Check if the primary and secondary coil is open or shorted. * Resistance of primary coil: Approx. 2.30 Ω Resistance of secondary coil: Approx. 123 Ω 2) Check if the MGT Heater Voltage is approx. 3.3V AC. <b>Caution : High voltage !</b>	Replace.
	H.V.Capacitor	Check continuity of capacitor between two terminals with H.V.wire lead removed. The resistance should be approx. 10MΩ, it's failure.	Replace.
	H.V.Diode	1) If there is no continuity in forward, direction the H.V.Diode is open. 2) If there is continuity in reverse direction, it's shorted.	Replace.
Fan motor does not rotate.	Fan motor	Check if the motor coil is open.	Replace.

# 7. Exploded Views and Parts List

## 7-1 Exploded Views

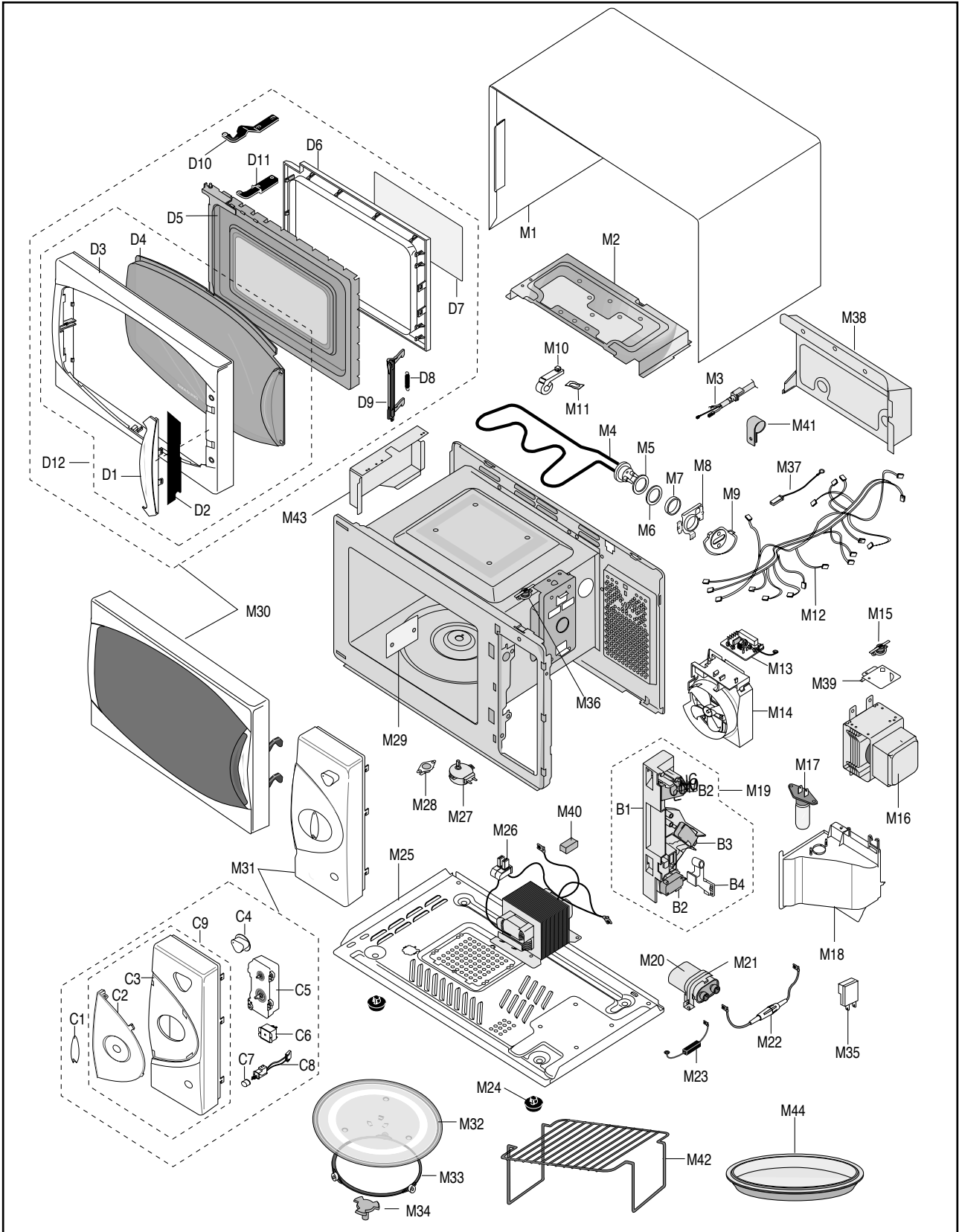

## 7-2 Main Parts List CE2914 / CE2914T

Ref. No.	Parts No.	Description	Specification	Q'ty	Remarks
M 1	DE70-30001A	PANEL-OUTER	SECC,T0.6,360,1128,EPOXY-COATI	1	
M 2	DE61-50575A	BRACKET-UPPER	SECC,T0.5,-,-,-,3RD	1	
M 3	DE39-20058M	ASSY POWER CORD	250V15A,1.5MM,GRY,KDK KKP(4819D)	1	
M 4	DE47-00001A	HEATER	230V,1250W,-,-,SHG-2933E	1	
M 5	DE63-20017A	GASKET-HEATER	BRASS,T1.5,OD30.5,ID22.5	1	
M 6	DE60-40009B	WASHER-TEFLON	SLOT,ID22.2,OD28,T1.2,TEFLON	1	
M 7	DE61-50021A	BRACKET-FLANGE	SECC1,T0.8,32,32	1	
M 8	DE61-50025A	BRACKET-EARTH	BSS2-A,T1.0,CE745G	1	
M 9	DE61-50027B	BRACKET-HEATER	SECC,T1.0,W51,L55,CE945GF	1	
M10	DE61-30006A	SUPPORTER-HEATER	ALUMINA,5G,2ND-W/P	1	
M11	DE61-70060A	SPRING-PLATE	SK-5,T0.5	1	
M12	DE39-00048A	WIRE HARNESS-A	,230V50HZ,-,-,CE2914,SEF,VDE	1	
M13	DE96-00008C	ASSY NOISE FILTER	SN-3WEH,250V15A,3W INRUSH D	1	
M14	DE31-00002B	MOTOR-FAN	SMF-3RDEA1,-,230V50HZ,2350RPM,CE2933	1	
M15	DE47-20009A	THERMOSTAT	PW2N-520PB,160/60,250V/7.5A,H	1	
M16	OM75PH(31)ESS	MAGNETRON	-	1	▲
M17	4713-001031	LAMP-INCANDESCENT	230V,173mA,40W,ORG,-,-,25x69mm	1	
M18	DE71-60458A	COVER-AIR	PP(TB53),78G,-,-,WHT,3RD-1.0/1.3 MW5896W	1	
M19	DE93-20020A	ASSY BODY LATCH	RE-43B/90B	1	
M20	2501-001107	C-OIL	1.1uF,2.1KV,BK,54x35x85,20mm	1	
M21	DE61-50106A	BRACKET-HVC	SECC,T0.8,W31,L125.8	1	
M22	DE91-70061A	ASSY-H.V.FUSE	THV060T-0800-H,5KV/0.8A,WHT	1	
M23	DE91-70063A	ASSY-HVD	V2M6,PI9.0,0.05MT	1	
M24	DE61-50579A	FOOT	PP,H8,PI15.8x16.1,-,BLK,3RD	2	
M25	DE80-10001G	BASE-PLATE	SGCC,T0.8,W345,L565,3RD	1	
M26	DE26-00008A	TRANS-H.V	SHV-293EC,230V50HZ,2230V/3.15V,-,DY	1	▲
M27	DE31-10154A	MOTOR-DRIVE	M2HJ49ZRO2,ST-16,50/60HZ	1	
M28	DE47-00003A	THERMOSTAT	PW2N,-,-,-,120/110,-,-,-,187,30.0	1	CVT-TCO
M29	DE71-00015A	COVER-CEILING	T0.3,W114.2,L121.5,-,CE2933	1	
M30	DE94-00176C	ASSY DOOR	CE2974,WHT	1	▲
M31	DE94-00139A	ASSY CONTROL-BOX	230V50HZ,CE2914,WHT,FISH2	1	CE2914 ▲
M31	DE94-00139E	ASSY CONTROL-BOX	230V50HZ,CE2914T/XET,WHT,FISH2	1	CE2914T ▲
M32	DE74-20015B	TRAY-COOKING	GLASS,T6.0,PI318,1050G,MW5630T	1	
M33	DE92-90189U	ASSY-GUIDE ROLLER	1.0CUFT(PPS)15.5	1	
M34	DE67-60081A	COUPLER	PPS,-,-,-,3RD-1.0/1.3	1	
M35	DE27-10020C	COIL-CHOKE	TC-104,0.9UH*2,-,L31*W20*H32,-,ABS,AC250V/14	1	
M36	DE47-00002A	THERMOSTAT	PW2N,-,-,-,100,110	1	GRILL-TCO
M37	DE39-40409A	WIRE HARNESS-E	230V50HZ,M9G45,CTW,	1	
M38	DE97-00083A	ASSY-COVER BACK	3RD-GRILL,BACK COVER+LABEL	1	
M39	DE61-50490A	BRACKET-TCO	SECC1,T0.6,34,58	1	
M40	DE63-90062B	CUSHION-RUBBER DOOR	RUBBER(CR),T12,W30,L50,HS60,M2	1	
M41	DE65-20014A	CABLE CLAMP	DA-6N,NY-66	1	P-CORD
M42	DE74-70081A	RACK-WIRE	HSWR,PI3,W268,H110,-,MW5584W	1	
M43	DE62-20064A	DUCT-AIR	SECC1-P,T0.5	1	
M44	DE74-20107A	TRAY-BROILER	AL,T0.8,345,345,PI345,ENAMEL	1	CE2914T

### 7-3 Door Parts List CE2914 / CE2914T

Ref. No.	Parts No.	Description	Specification	Q'ty	Remarks
D 1	DE64-20112D	HANDLE-DOOR	ABS(HR0370U),30G,WHT,-,M959	1	
D 2	DE01-00098A	FILM-DOOR	PET,T0.13,W22.6,L201.8,-,M959	1	
D 3	DE64-40263F	DOOR-A	ABS(HR0370U),160G,WHT,-,M959	1	
D 4	DE64-40265L	DOOR-SCREEN	SAN,-,-,-,SMOG,CE2914/XEC,3RD-1.0 FISH2	1	▲
D 5	DE94-00075B	ASSY DOOR-E	3RD-1.0,BLK,COATING	1	
D 6	DE64-40012A	DOOR-C	RESIN-PP(TB53),T2.0,CE945GF,BL	1	
D 7	DE01-00118B	FILM-DOOR	T0.15,W295,L185,-,-,CE2933	1	
D 8	DE61-70126A	SPRING-KEY	0.8,0,36,6,BLUIING	1	
D 9	DE64-40264C	DOOR-KEY	POM(F20-02),5g,BLK,-,2ND HANDL	1	
D10	DE61-80002A	HINGE-UPPER	SCP1,T2.3,26,77,ZPC3,WHT,CE945	1	
D11	DE61-80003A	HINGE-LOWER	SCP1,T2.3,26,77,ZPC3,WHT,CE945	1	
D12	DE94-00173D	ASSY DOOR-A	CE2974,WHT	1	

### 7-4 Control Parts List CE2914 / CE2914T

Ref. No.	Parts No.	Description	Specification	Q'ty	Remarks
C 1	DE64-00007A	KNOB-TIMER	ABS,10G,WHT,20X47X35,M1914	1	
C 2	DE71-00001B	COVER-PANEL	ABS,-,-,-,WHT,3RD-1.0 FISH2	1	
C 3	DE72-00007B	CONTROL-PANEL	ABS,CE2914,3RD-1.0 FISH-2,-,-,-,WHT	1	CE2914
C 3	DE72-00007N	CONTROL-PANEL	ABS,CE2914T/XET,-,-,-,-,WHITE,3RD-1.0 FISH-2	1	CE2914T
C 4	DE64-00006A	KNOB-POWER	ABS,10G,WHT,-,M1974	1	
C 5	DE45-00005A	TIMER	TMFK60M1B1,-,-,-,FISH-DESIGN,-,-,310-GRILL	1	
C 6	3501-000309	RELAY-POWER	240V,3750VA,15A,-,6mS,20mS	1	
C 7	DE66-00009A	BUTTON-SELECT(A)	ABS,-,D10,WHT,3G	1	-
C 8	DE39-00059A	WIRE HARNESS-SWITCH	230V50HZ,T/TABLE S/W,-,M1914,EUROPE	1	
C 9	DE94-00150B	ASSY CONTROL-PANEL	CE2914,WHT,3RD-1.0 FISH-2	1	CE2914
C 9	DE94-00150H	ASSY CONTROL-PANEL	CE2914T/XET,WHITE,3RD-1.0,FISH2	1	CE2914T

### 7-5 Body Latch Parts List CE2914 / CE2914T

Ref. No.	Parts No.	Description	Specification	Q'ty	Remarks
B 1	DE66-40021A	LATCH-BODY	POM(F20-02),50G,RE-330	1	
B 2	3405-000178	SWITCH-MICRO	250V,15A,200gf,SPST-NO	2	
B 3	3405-000175	SWITCH-MICRO	250V,15A,200gf,SPST-NO	1	
B 4	DE66-90054A	LEVER-SWITCH	POM(F20-02),15G,NTR,RE-330	1	

● : Option Parts

▲ : Warning

▲ :Electrostatically Sensitive Devices

## 7-6 Standard Parts List

Parts No.	Description	Specification	Q'ty	Remarks
DE60-10012A	SCREW-TAP TITE	TH,+3,M4,L10,SWR10,ZPC2,TOOTH	1	N-F-EA
DE60-10012A	SCREW-TAP TITE	TH,+3,M4,L10,SWR10,ZPC2,TOOTH	1	P-C-EA
DE60-10013A	SCREW-ASSY TAP	TH,2S,4,L12,MSWR3,ZPC3,FIBER	1	MO/FAN
DE60-10018A	SCREW-ASSY MACHINE	PH,M4X0.7P,8,MSWR10,SN1,WS	2	B/EATH
DE60-10024A	SCREW-PH	PH,+M4,L8,MSWR10,ZPC3	2	B/HEAT
DE60-10045A	SCREW-TAP PH	PH,M3,L6,FEFZY	2	MG-TCO
DE60-10069A	SCREW-TAP TH	TH,M4,L10,FRFZY	3	B/UPPE
DE60-10069A	SCREW-TAP TH	TH,M4,L10,FRFZY	1	CV/AIR
DE60-10072A	SCREW-TAP TH	TH,M4,L16,FEFZY,2-SLOT	1	CB-CMP
DE60-10080A	SCREW-WASHER	M5,L12,2S	4	MGT
DE60-10080A	SCREW-WASHER	M5,L12,2S	4	TNS-HV
DE60-10082H	SCREW-A	2S-4X12,TOOTHED	2	B-PLTE
DE60-10082H	SCREW-A	2S-4X12,TOOTHED	2	CN-BOX
DE60-10082H	SCREW-A	2S-4X12,TOOTHED	2	LATCH
DE60-10082H	SCREW-A	2S-4X12,TOOTHED	5	PN-OUT
DE60-10098A	SCREW-ASSY TAP TITE	PH,TC,M4X8,SWRCH18A,ZPC2,GLD,W	1	CV-TCO
DE60-10098A	SCREW-ASSY TAP TITE	PH,TC,M4X8,SWRCH18A,ZPC2,GLD,W	2	M/DRIV
DE60-10122A	SCREW-TAP TH	TAP,TH,2-4X8,FE,FN	2	C-CEIL
DE60-20063A	BOLT-FLANGE	M4,10,ZPC3,YEL,MSWR	2	HI-LOW
DE60-20063A	BOLT-FLANGE	M4,10,ZPC3,YEL,MSWR	2	HI-UPP
DE60-10045A	SCREW-TAP PH	PH,M3,L6,FEFZY	1	-
DE60-10069A	SCREW-TAP TH	TH,M4,L10,FRFZY	1	AC-REL
DE60-10072A	SCREW-TAP TH	TH,M4,L16,FEFZY,2-SLOT	4	TIMER
DE60-10088A	SCREW-TAP PH	PH,M3,L8,FEFZY,PLAIN	1	T/T
DE60-10069A	SCREW-TAP TH	TH,M4,L10,FRFZY	2	-
DE60-10082J	SCREW-TAPPING	TH,2S-4X8,MSWR3,ZPC,YEL,WS	1	HVC
DE60-10012A	SCREW-TAP TITE	TH,+3,M4,L10,SWR10,ZPC2,TOOTH	1	-

# 8. Schematic Diagrams

## 8-1 Schematic Diagrams

NOTE: CIRCUIT SHOWN WITH DOOR IS OPENED POSITION.  
 NOTE: FOR SERVICE REPLACEMENT USE 16 GA 105°C  
 THERMOPLASTIC COVERED WIRE EXCEPT  
 FOR HIGH VOLTAGE LEADS OR AS NOTED ON SPECIAL LEADS.

**WARNING**  
 POWER MUST BE DISCONNECTED  
 BEFORE SERVICING THIS APPLIANCE

