

1. Main

Exploded View

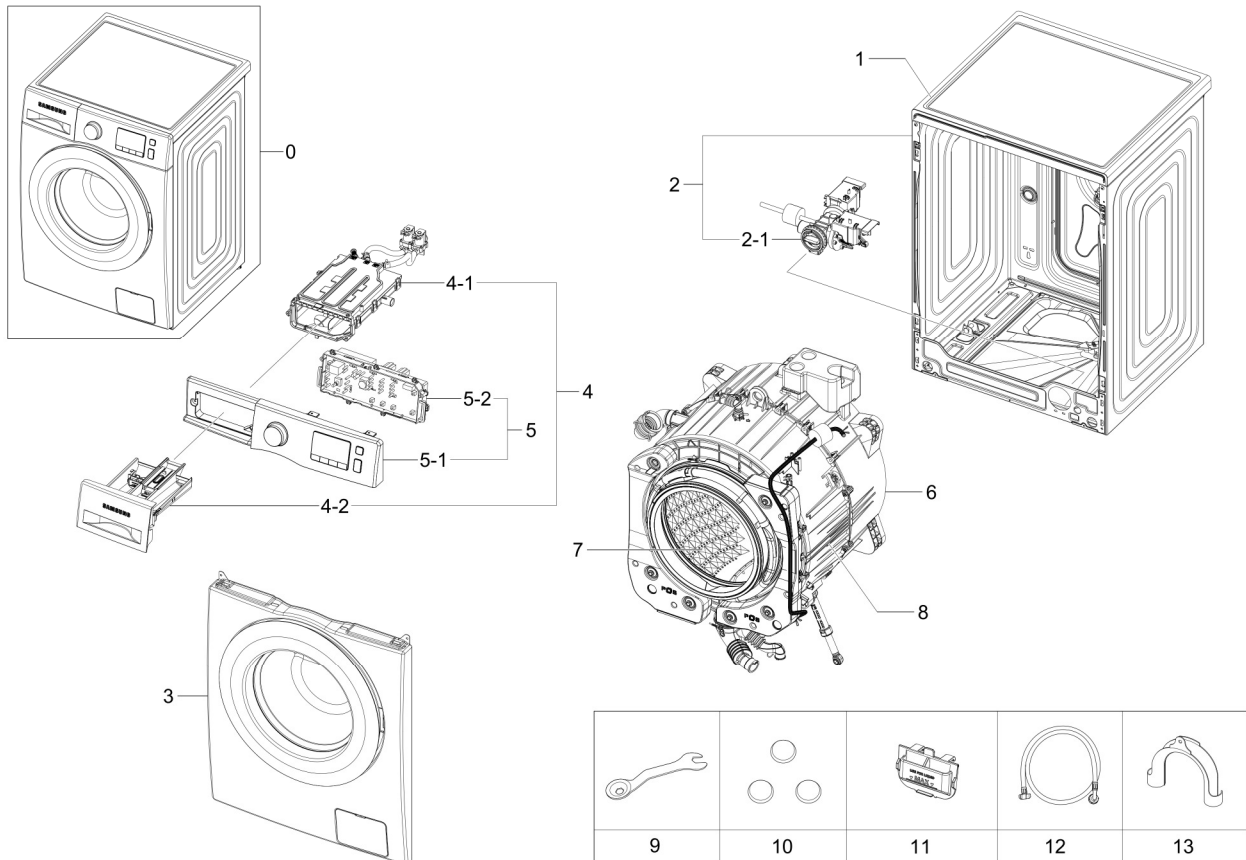

Parts List

No.	Lvl.	Loc.	Material Code	Description & Specification	SNA	Qty.
1	1	W0183		ASSY COVER TOP; F500,UNI,WHT	SNA	1
2	1	W0506		ASSY FRAME; F500 9kg,wht, UNI	SNA	1
2-1	2	W0194		ASSY PUMP DRAIN; F500E,WF80F5E5U4W/EF,AL-	SA	1
3	1			ASSY FRONT; F500E,WF80F5E5U4W/EF	SNA	1
4	1	W0216		ASSY DRAWER; UNI,WHITE COLOR,9kg	SNA	1
4-1	2	W0163		ASSY HOUSING DRAWER; F500E,WF80F50FU4W,PP	SA	1
4-2	2	W0216		ASSY DRAWER; F500E,WF90F5E5U4W	SA	1
5	1	W0478		ASSY PANEL CONTROL; F500,9kg,EC,BETTER	SNA	1
5-1	2	W0478		ASSY PANEL CONTROL; WF90F5E2W2W/EC,SPAIN,	SA	1
5-2	2			ASSY KIT; ASSY KIT,F550E 9kg, better,230V	SA	1
6	1	W0501		ASSY TUB BACK; F500,CERAMIC	SNA	1
7	1	W0165		ASSY DRUM; F500E,WF80F5E5U4W/EF	SNA	1

2. Assy Frame&Cover Parts

Exploded View

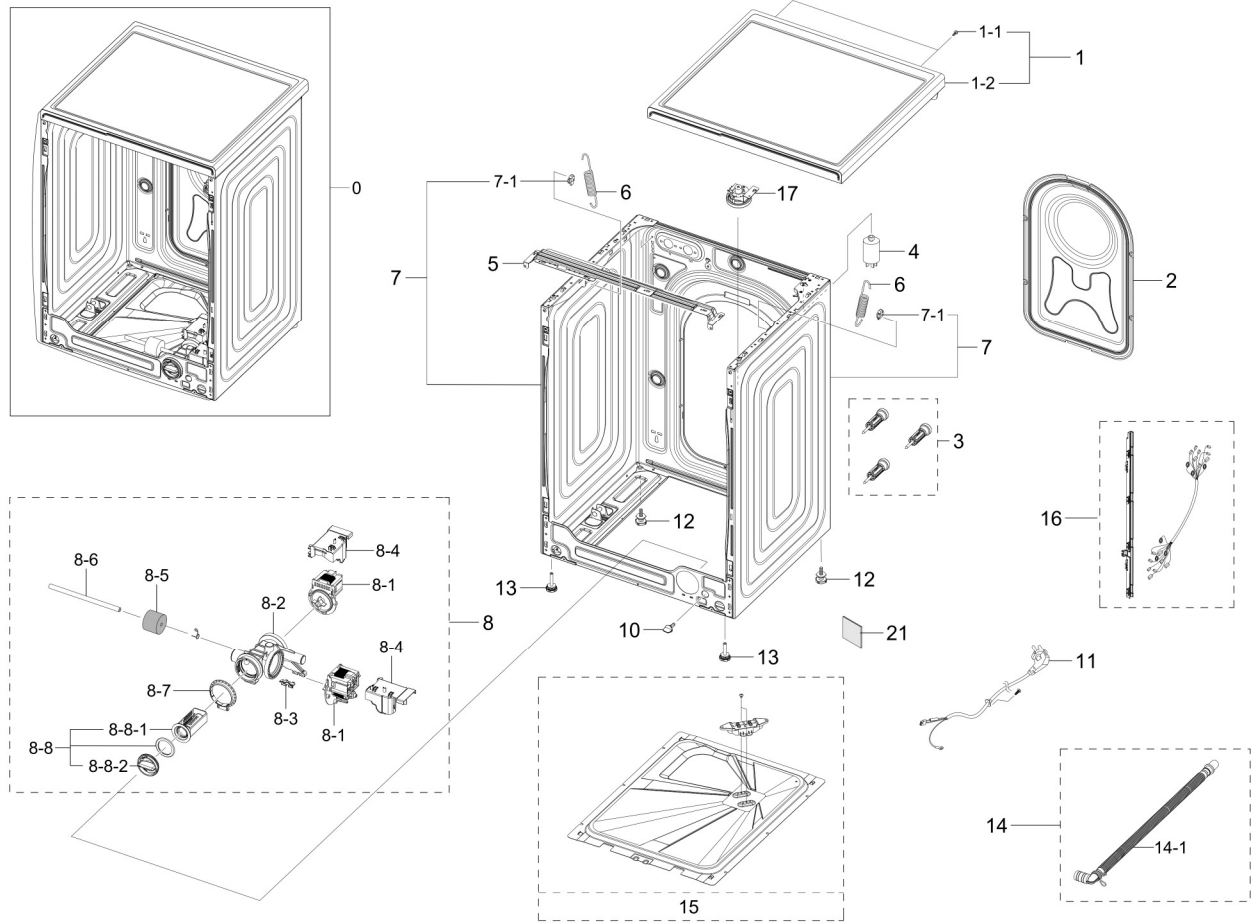

Parts List

No.	Lvl.	Loc.	Material Code	Description & Specification	SNA	Qty.
1	1	W0183		ASSY COVER TOP; F500,UNI,WHT	SNA	1
1-1	2	G0425		SCREW-HEX; HEX,+,M5,L10,Ni-Zn(WHT),SWRCH1	SA	2
1-2	2	W0183		ASSY COVER TOP; F500E,WHITE	SA	1
2	2	G0430		ASSY COVER BACK; F400E	SA	1
3	2	W0603		ASSY FIXER TUB; SCOUT,WF0804Y8E/XEF	SA	3
4	2	W0229		FILTER-EMI; FA-2151T-4 / RDFC-2718,1.2mm	SA	1
5	2	W0248		FRAME-PLATE(U); WF-F500E,G1-SGCC,-,-,T1.0	SNA	1
6	2	W0630		SPRING ETC-HANGER; F500E PJT,HSWR-SWRH,CD	SA	2
7	2	W0506		ASSY FRAME; F500E,DA WHITE,COLD,UNI	SA	1
7-1	3	W0140		GUIDE-SPRING; WF448AAG/XXA,POM,T4,W24,L36	SA	2

3. Assy Tub&Drum

Exploded View

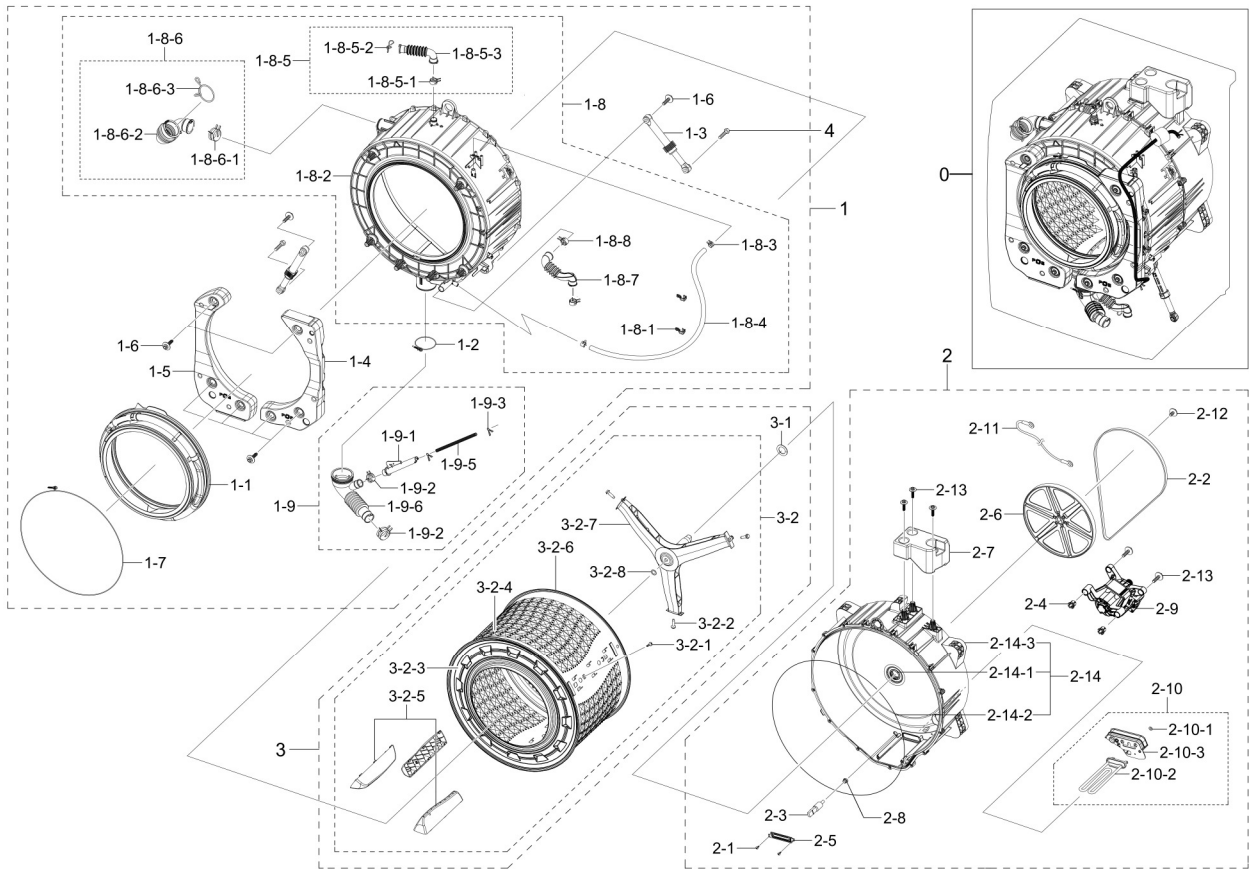

Parts List

No.	Lvl.	Loc.	Material Code	Description & Specification	SNA	Qty.
1	1	G0048		ASSY TUB FRONT; F500E,WF80F5E5U4W/EF	SNA	1
1-1	2	W0234		DOOR-DIAPHRAGM; WF80F5E5U4W,TPE,T2.4,H80.	SA	1
1-2	2	W0744		CLAMPER HOSE-JOINT; HEBA PJT,HSWR-SWRH,ID	SA	1
1-3	2	W0618		DAMPER-SHOCK; HEBA,STEEL+PP+RUBBER,80N,W2	SA	2
1-4	2	W0232		WEIGHT-BALANCER(R); F500,CONCRETE,W238,L4	SA	1
1-5	2	W0233		WEIGHT-BALANCER(L); F500,CONCRETE,W238,L5	SA	1
1-6	2	W0601		ASSY BOLT; HEBA-PJT,MOTOR/BOLT(M8)+WASHER	SA	5
1-7	2	M0038		ASSY CLAMP DIAPHRAGM; WF8804DP,OD2.0/L124	SA	1

5. Assy Panel Control

Exploded View

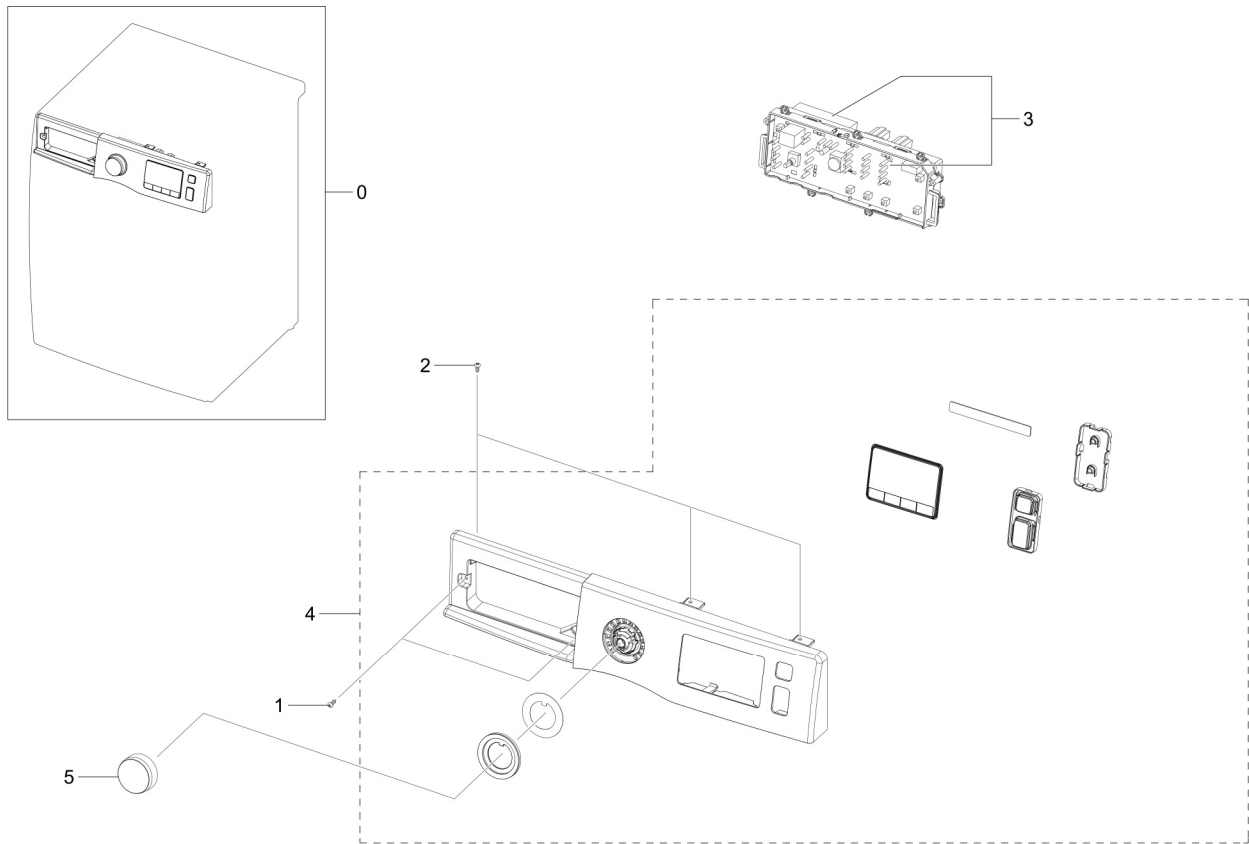

Parts List

No.	Lvl.	Loc.	Material Code	Description & Specification	SNA	Qty.
0	1	W0478		ASSY PANEL CONTROL; F500,9kg,EC,BETTER	SNA	1
1	2	W0105		SCREW-TAPPING; TH,+,NO,2,M4,L18,PASS,STS4	SNA	2
2	2	W0105		SCREW-TAPPING; TH,+,-,2,M4,L12,ZPC(WHT),S	SNA	1
3	2			ASSY KIT; ASSY KIT,F550E 9kg, better,230V	SA	1
4	2	W0478		ASSY PANEL CONTROL; WF90F5E2W2W/EC,SPAIN,	SA	1
5	2	W0475		ASSY KNOB ENCODER; WF80F50FU4W/EF	SA	1

6. Assy Drawer

Exploded View

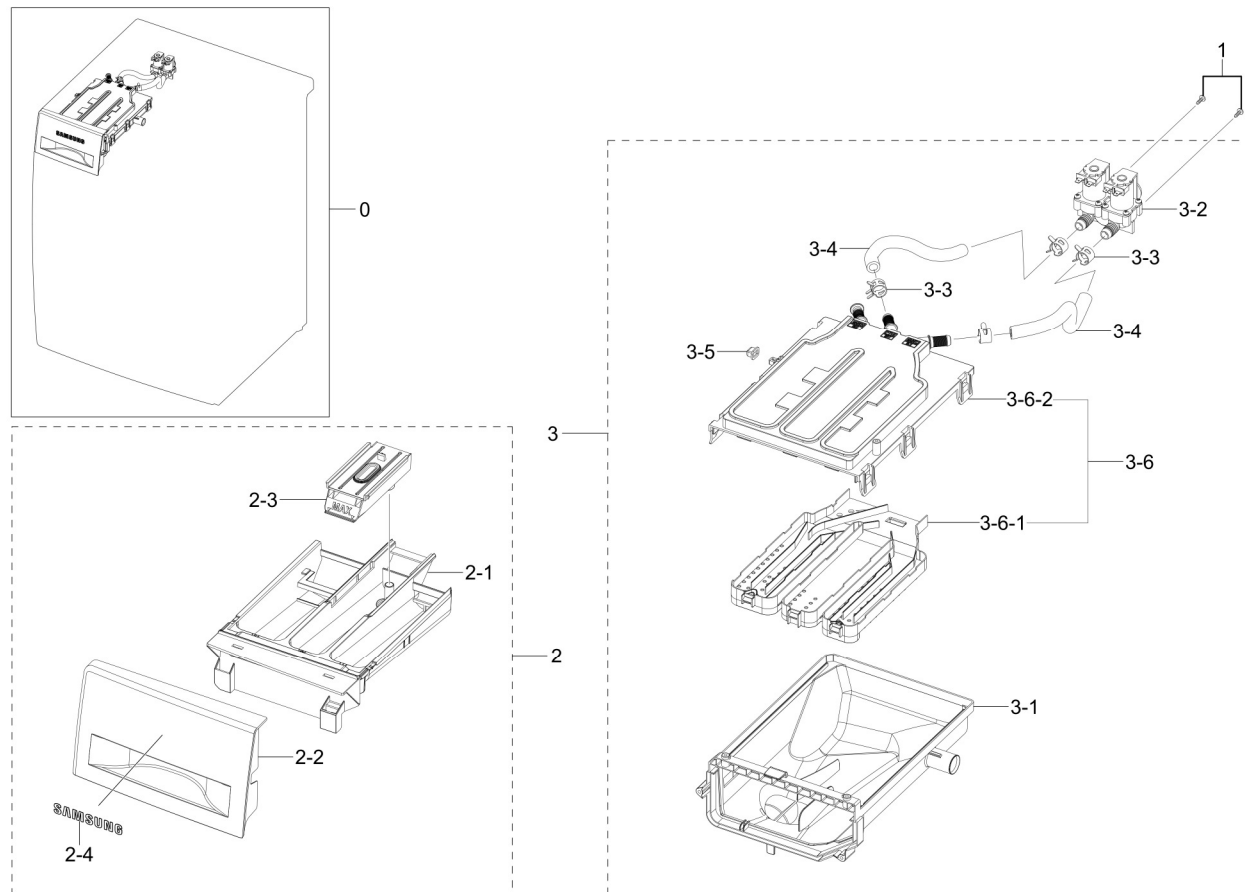







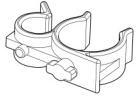

Parts List

No.	Lvl.	Loc.	Material Code	Description & Specification	SNA	Qty.
0	1	W0216		ASSY DRAWER; UNI,WHITE COLOR,9kg	SNA	1
1	2	F0055		SCREW-TAPTYPE; TH,+,-,S,M4,L8,ZPC(WHT),SW	SC	2
2	2	W0216		ASSY DRAWER; F500E,WF90F5E5U4W	SA	1
2-1	3	W0156		BODY-DRAWER; WF-F500E,PP,White,F500, 8kg	SA	1
2-2	3			PANEL DRAWER; WF90F5E5U4W,ABS,-,HG-0760GP	SA	1
2-3	3	W0215		CAP-RINSE; WF-F500E,PP,-,-,ECO BLUE,F500	SA	1
2-4	3	M0196		MASCOT; ALL,NICKEL,T0.05,L65	SA	1
3	2	W0163		ASSY HOUSING DRAWER; F500E,WF80F50FU4W,PP	SA	1
3-1	3	W0372		HOUSING-DRAWER(L); WF-F500E,PP,-,WHITE,-,	SA	1
3-2	3	W0078		VALVE WATER; 220-240,10,D-2	SC	1

7. Small Parts

Exploded View

				
1	2	3	4	5
				
6	7	8	9	

Parts List

No.	Lvl.	Loc.	Material Code	Description & Specification	SNA	Qty.
1	2	W0616		CLAMPER HOSE-FIX; P1291,PP,-,HOSE+PLUG,BJ	SA	1
2	2	W0616		CLAMPER HOSE-FIX; P1291,PA66,ID27,OD30	SA	1
3	2	W0623		HOLDER-WIRE; DAWH-2NC,PA,-,NATURAL,-	SA	5
4	2	W0623		HOLDER-WIRE; DAWH-3ND,NYLON66,NTR(PI24.4)	SA	1
5	2	M0001		HOLDER-WIRE SADDLE; PA,NTR,NYLON66	SA	3
6	2			CABLE CLAMP; DA-9N-1,NYLON66,NTR	SNA	1
7	2			CABLE CLAMP; DAWH-18NB,ID15,-,NYLON66,NTR	SA	1
8	2	W0623		HOLDER-WIRE; HEBA-PJT,PA,ID26,W6,L145,NYL	SA	1
9	2	G0040		WIRE-VINYL; SEW-100JL,PVC,T2.0*L150	SA	2